

TOSHIBA

FILE NO. SVM-12085-1

SERVICE MANUAL

AIR-CONDITIONER (SPLIT TYPE)

**OUTDOOR UNIT
<SUPER DIGITAL INVERTER>**

RAV-SP404ATP-E

RAV-SP454ATP-E

RAV-SP564ATP-E

RAV-SP564ATJP-E

RAV-SP804ATP-E

RAV-SP804ATJP-E



Original instruction**Adoption of New Refrigerant**

This Air Conditioner is a new type which adopts a new refrigerant HFC (R410A) instead of the conventional refrigerant R22 in order to prevent destruction of the ozone layer.

CONTENTS

SAFETY CAUTION	3
1. SPECIFICATIONS	14
1-1. Outdoor Unit	14
1-2. Operation Characteristic Curve	15
2. CONSTRUCTION VIEWS (EXTERNAL VIEWS)	17
2-1. RAV-SP40*ATP*, SP45*ATP*, SP56*ATP*	17
2-2. RAV-SP80*ATP*	18
3. SYSTEMATIC REFRIGERATING CYCLE DIAGRAM	20
3-1. Indoor Unit	20
3-2. Outdoor Unit	21
4. WIRING DIAGRAM	24
4-1. RAV-SP40*ATP*, SP45*ATP*, SP56*ATP*	24
4-2. RAV-SP80*ATP*	25
5. SPECIFICATIONS OF ELECTRICAL PARTS	26
6. REFRIGERANT R410A	27
6-1. Safety During Installation/Serviceing	27
6-2. Refrigerant Piping Installation	27
6-3. Tools	31
6-4. Recharging of Refrigerant	31
6-5. Brazing of Pipes	32
6-6. Instructions for Re-use Piping of R22 or R407C	34
6-7. Replenishing refrigerant	37
7. OUTDOOR CONTROL CIRCUIT	38
7-1. Outdoor Controls	38
7-2. Outdoor Print Circuit Board	45
8. TROUBLESHOOTING	47
8-1. Summary of Troubleshooting	47
8-2. Troubleshooting	49
8-3. Table Inspection of outdoor unit main parts	74
9. OTHERS	75
9-1. Refrigerant Recovery Control	75
9-2. Various Setting on Outdoor Unit (Existing piping, Power save, Cooling-only, etc.)	76
9-3. Service Support Function (LED Display, Switch Operation)	77
10. DETACHMENTS	83
10-1. RAV-SP40*ATP*, SP45*ATP*, SP56*ATP*	83
10-2. RAV-SP80*ATP*	91
11. EXPLODED VIEWS AND PARTS LIST	101
11-1. RAV-SP404ATP-E, SP454ATP-E	101
11-2. SP564ATP-E, SP564ATJP-E	105
11-3. RAV-SP804ATP-E, SP804ATJP-E	109

SAFETY CAUTION

Please read carefully through these instructions that contain important information which complies with the “Machinery” Directive (Directive 2006/42/EC), and ensure that you understand them.

Generic Denomination: Air Conditioner

Definition of Qualified Installer or Qualified Service Person

The air conditioner must be installed, maintained, repaired and removed by a qualified installer or qualified service person.

When any of these jobs is to be done, ask a qualified installer or qualified service person to do them for you.

A qualified installer or qualified service person is an agent who has the qualifications and knowledge described in the table below.

Agent	Qualifications and knowledge which the agent must have
Qualified installer (*1)	<ul style="list-style-type: none"> • The qualified installer is a person who installs, maintains, relocates and removes the air conditioners made by Toshiba Carrier Corporation. He or she has been trained to install, maintain, relocate and remove the air conditioners made by Toshiba Carrier Corporation or, alternatively, he or she has been instructed in such operations by an individual or individuals who have been trained and is thus thoroughly acquainted with the knowledge related to these operations. • The qualified installer who is allowed to do the electrical work involved in installation, relocation and removal has the qualifications pertaining to this electrical work as stipulated by the local laws and regulations, and he or she is a person who has been trained in matters relating to electrical work on the air conditioners made by Toshiba Carrier Corporation or, alternatively, he or she has been instructed in such matters by an individual or individuals who have been trained and is thus thoroughly acquainted with the knowledge related to this work. • The qualified installer who is allowed to do the refrigerant handling and piping work involved in installation, relocation and removal has the qualifications pertaining to this refrigerant handling and piping work as stipulated by the local laws and regulations, and he or she is a person who has been trained in matters relating to refrigerant handling and piping work on the air conditioners made by Toshiba Carrier Corporation or, alternatively, he or she has been instructed in such matters by an individual or individuals who have been trained and is thus thoroughly acquainted with the knowledge related to this work. • The qualified installer who is allowed to work at heights has been trained in matters relating to working at heights with the air conditioners made by Toshiba Carrier Corporation or, alternatively, he or she has been instructed in such matters by an individual or individuals who have been trained and is thus thoroughly acquainted with the knowledge related to this work.
Qualified service person (*1)	<ul style="list-style-type: none"> • The qualified service person is a person who installs, repairs, maintains, relocates and removes the air conditioners made by Toshiba Carrier Corporation. He or she has been trained to install, repair, maintain, relocate and remove the air conditioners made by Toshiba Carrier Corporation or, alternatively, he or she has been instructed in such operations by an individual or individuals who have been trained and is thus thoroughly acquainted with the knowledge related to these operations. • The qualified service person who is allowed to do the electrical work involved in installation, repair, relocation and removal has the qualifications pertaining to this electrical work as stipulated by the local laws and regulations, and he or she is a person who has been trained in matters relating to electrical work on the air conditioners made by Toshiba Carrier Corporation or, alternatively, he or she has been instructed in such matters by an individual or individuals who have been trained and is thus thoroughly acquainted with the knowledge related to this work. • The qualified service person who is allowed to do the refrigerant handling and piping work involved in installation, repair, relocation and removal has the qualifications pertaining to this refrigerant handling and piping work as stipulated by the local laws and regulations, and he or she is a person who has been trained in matters relating to refrigerant handling and piping work on the air conditioners made by Toshiba Carrier Corporation or, alternatively, he or she has been instructed in such matters by an individual or individuals who have been trained and is thus thoroughly acquainted with the knowledge related to this work. • The qualified service person who is allowed to work at heights has been trained in matters relating to working at heights with the air conditioners made by Toshiba Carrier Corporation or, alternatively, he or she has been instructed in such matters by an individual or individuals who have been trained and is thus thoroughly acquainted with the knowledge related to this work.

Definition of Protective Gear

When the air conditioner is to be transported, installed, maintained, repaired or removed, wear protective gloves and “safety” work clothing.



In addition to such normal protective gear, wear the protective gear described below when undertaking the special work detailed in the table below.

Failure to wear the proper protective gear is dangerous because you will be more susceptible to injury, burns, electric shocks and other injuries.

Work undertaken	Protective gear worn
All types of work	Protective gloves “Safety” working clothing
Electrical-related work	Gloves to provide protection for electricians and from heat Insulating shoes Clothing to provide protection from electric shock
Work done at heights (50 cm or more)	Helmets for use in industry
Transportation of heavy objects	Shoes with additional protective toe cap
Repair of outdoor unit	Gloves to provide protection for electricians and from heat



The important contents concerned to the safety are described on the product itself and on this Service Manual. Please read this Service Manual after understanding the described items thoroughly in the following contents (Indications/Illustrated marks), and keep them.

[Explanation of indications]

Indication	Explanation
 DANGER	Indicates contents assumed that an imminent danger causing a death or serious injury of the repair engineers and the third parties when an incorrect work has been executed.
 WARNING	Indicates possibilities assumed that a danger causing a death or serious injury of the repair engineers, the third parties, and the users due to troubles of the product after work when an incorrect work has been executed.
 CAUTION	Indicates contents assumed that an injury or property damage (*) may be caused on the repair engineers, the third parties, and the users due to troubles of the product after work when an incorrect work has been executed.

* Property damage : Enlarged damage concerned to property, furniture, and domestic animal/pet

[Explanation of illustrated marks]





Mark	Explanation
	Indicates prohibited items (Forbidden items to do) The sentences near an illustrated mark describe the concrete prohibited contents.
	Indicates mandatory items (Compulsory items to do) The sentences near an illustrated mark describe the concrete mandatory contents.
	Indicates cautions (Including danger/warning) The sentences or illustration near or in an illustrated mark describe the concrete cautious contents.

Warning Indications on the Air Conditioner Unit

[Confirmation of warning label on the main unit]

Confirm that labels are indicated on the specified positions





If removing the label during parts replace, stick it as the original.

Warning indication		Description
 <p>WARNING</p> <p>ELECTRICAL SHOCK HAZARD Disconnect all remote electric power supplies before servicing.</p>	<p>WARNING</p> <p>ELECTRICAL SHOCK HAZARD Disconnect all remote electric power supplies before servicing.</p>	
 <p>WARNING</p> <p>Moving parts. Do not operate unit with grille removed. Stop the unit before the servicing.</p>	<p>WARNING</p> <p>Moving parts. Do not operate unit with grille removed. Stop the unit before the servicing.</p>	
 <p>CAUTION</p> <p>High temperature parts. You might get burned when removing this panel.</p>	<p>CAUTION</p> <p>High temperature parts. You might get burned when removing this panel.</p>	
 <p>CAUTION</p> <p>Do not touch the aluminum fins of the unit. Doing so may result in injury.</p>	<p>CAUTION</p> <p>Do not touch the aluminum fins of the unit. Doing so may result in injury.</p>	
 <p>CAUTION</p> <p>BURST HAZARD Open the service valves before the operation, otherwise there might be the burst.</p>	<p>CAUTION</p> <p>BURST HAZARD Open the service valves before the operation, otherwise there might be the burst.</p>	

Precaution for Safety

The manufacturer shall not assume any liability for the damage caused by not observing the description of this manual.







DANGER







 Turn off breaker.	Before carrying out the installation, maintenance, repair or removal work, be sure to set the circuit breaker to the OFF position. Otherwise, electric shocks may result.
	Before opening the intake grille of the indoor unit or service panel or valve cover of the outdoor unit, set the circuit breaker to the OFF position. Failure to set the circuit breaker to the OFF position may result in electric shocks through contact with the interior parts. Only a qualified installer (*1) or qualified service person (*1) is allowed to remove the intake grille of the indoor unit or service panel of the outdoor unit and do the work required.
	Before starting to repair the outdoor unit fan or fan guard, be absolutely sure to set the circuit breaker to the OFF position, and place a "Work in progress" sign on the circuit breaker before proceeding with the work.
	When cleaning the filter or other parts of the indoor unit, set the circuit breaker to OFF without fail, and place a "Work in progress" sign near the circuit breaker before proceeding with the work.
 Electric shock hazard	When you access inside of the service panel to repair electric parts, wait for about five minutes after turning off the breaker. Do not start repairing immediately. Otherwise you may get electric shock by touching terminals of high-voltage capacitors. Natural discharge of the capacitor takes about five minutes.
	Before operating the air conditioner after having completed the work, check that the electrical parts box cover of the indoor unit and service panel or valve cover of the outdoor unit are closed, and set the circuit breaker to the ON position. You may receive an electric shock etc. if the power is turned on without first conducting these checks.
 Execute discharge between terminals.	Even if the circuit breaker has been set to the OFF position before the service panel is removed and the electrical parts are repaired, you will still risk receiving an electric shock. For this reason, short-circuit the high-voltage capacitor terminals to discharge the voltage before proceeding with the repair work. For details on the short-circuiting procedure, refer to the Service Manual. You may receive an electric shock if the voltage stored in the capacitors has not been sufficiently discharged.
 Prohibition	Place a "Work in progress" sign near the circuit breaker while the installation, maintenance, repair or removal work is being carried out. There is a danger of electric shocks if the circuit breaker is set to ON by mistake.
	When checking the electric parts, removing the cover of the electric parts box of Indoor Unit and/or front panel of Outdoor Unit inevitably to determine the failure, put a sign "Do not enter" around the site before the work. Failure to do this may result in third person getting electric shock.
 Stay on protection	If, in the course of carrying out repairs, it becomes absolutely necessary to check out the electrical parts with the electrical parts box cover of one or more of the indoor units and the service panel of the outdoor unit removed in order to find out exactly where the trouble lies, wear insulated heat-resistant gloves, insulated boots and insulated work overalls, and take care to avoid touching any live parts. You may receive an electric shock if you fail to heed this warning. Only qualified service person (*1) is allowed to do this kind of work.





WARNING

 General	Before starting to repair the air conditioner, read carefully through the Service Manual, and repair the air conditioner by following its instructions.
	Only qualified service person (*1) is allowed to repair the air conditioner. Repair of the air conditioner by unqualified person may give rise to a fire, electric shocks, injury, water leaks and/or other problems.
	Only a qualified installer (*1) or qualified service person (*1) is allowed to carry out the electrical work of the air conditioner. Under no circumstances must this work be done by an unqualified individual since failure to carry out the work properly may result in electric shocks and/or electrical leaks.
	Wear protective gloves and safety work clothing during installation, servicing and removal.

WARNING

 General	<p>Use wiring that meets the specifications in the Installation Manual and the stipulations in the local regulations and laws. Use of wiring which does not meet the specifications may give rise to electric shocks, electrical leakage, smoking and/or a fire.</p>
	<p>The appliance shall be installed in accordance with national wiring regulations. Capacity shortages of the power circuit or an incomplete installation may cause an electric shock or fire.</p>
	<p>Only a qualified installer (*1) or qualified service person (*1) is allowed to undertake work at heights using a stand of 50 cm or more.</p>
	<p>When working at heights, use a ladder which complies with the ISO 14122 standard, and follow the procedure in the ladder's instructions. Also wear a helmet for use in industry as protective gear to undertake the work.</p>
	<p>When working at heights, put a sign in place so that no-one will approach the work location, before proceeding with the work. Parts and other objects may fall from above, possibly injuring a person below.</p>
	<p>Do not touch the aluminum fin of the outdoor unit. You may injure yourself if you do so. If the fin must be touched for some reason, first put on protective gloves and safety work clothing, and then proceed.</p>
	<p>Do not climb onto or place objects on top of the outdoor unit. You may fall or the objects may fall off of the outdoor unit and result in injury.</p>
	<p>When transporting the air conditioner, wear shoes with additional protective toe caps.</p>
	<p>When transporting the air conditioner, do not take hold of the bands around the packing carton. You may injure yourself if the bands should break.</p>
	<p>When transporting the air conditioner, use a forklift and when moving the air conditioner by hand, move the unit with 4 people.</p>
	<p>Do not customize the product. Doing so may result in electric shock or other failure. This air conditioner has passed the pressure test as specified in IEC 60335-2-40 Annex EE.</p>
 Check earth wires.	<p>Before troubleshooting or repair work, check the earth wire is connected to the earth terminals of the main unit, otherwise an electric shock is caused when a leak occurs. If the earth wire is not correctly connected, contact an electric engineer for rework.</p>
	<p>After completing the repair or relocation work, check that the ground wires are connected properly.</p>
	<p>Be sure to connect earth wire. (Grounding work) Incomplete grounding causes an electric shock. Do not connect ground wires to gas pipes, water pipes, and lightning rods or ground wires for telephone wires.</p>
 Prohibition of modification.	<p>Do not modify the products. Do not also disassemble or modify the parts. It may cause a fire, electric shock or injury.</p>
 Use specified parts.	<p>When any of the electrical parts are to be replaced, ensure that the replacement parts satisfy the specifications given in the Service Manual (or use the parts contained on the parts list in the Service Manual). Use of any parts which do not satisfy the required specifications may give rise to electric shocks, smoking and/or a fire.</p>
 Do not bring a child close to the equipment.	<p>If, in the course of carrying out repairs, it becomes absolutely necessary to check out the electrical parts with the electrical parts box cover of one or more of the indoor units and the service panel of the outdoor unit removed in order to find out exactly where the trouble lies, place "Keep out" signs around the work site before proceeding. Third-party individuals may enter the work site and receive electric shocks if this warning is not heeded.</p>
 Insulating measures	<p>Connect the cut-off lead wires with crimp contact, etc, put the closed end side upward and then apply a water-cut method, otherwise a leak or production of fire is caused at the users' side.</p>
 No fire	<p>When performing repairs using a gas burner, replace the refrigerant with nitrogen gas because the oil that coats the pipes may otherwise burn.</p>
	<p>When repairing the refrigerating cycle, take the following measures. 1) Be attentive to fire around the cycle. When using a gas stove, etc, be sure to put out fire before work; otherwise the oil mixed with refrigerant gas may catch fire. 2) Do not use a welder in the closed room. When using it without ventilation, carbon monoxide poisoning may be caused. 3) Do not bring inflammables close to the refrigerant cycle, otherwise fire of the welder may catch the inflammables.</p>

 Refrigerant	<p>The refrigerant used by this air conditioner is the R410A.</p>
	<p>Check the used refrigerant name and use tools and materials of the parts which match with it. For the products which use R410A refrigerant, the refrigerant name is indicated at a position on the outdoor unit where is easy to see. To prevent miss-charging, the route of the service port is changed from one of the former R22.</p>
	<p>Do not use any refrigerant different from the one specified for complement or replacement. Otherwise, abnormally high pressure may be generated in the refrigeration cycle, which may result in a failure or explosion of the product or an injury to your body.</p>
	<p>For an air conditioner which uses R410A, never use other refrigerant than R410A. For an air conditioner which uses other refrigerant (R22, etc.), never use R410A. If different types of refrigerant are mixed, abnormal high pressure generates in the refrigerating cycle and an injury due to breakage may be caused.</p>
	<p>Do not charge refrigerant additionally. If charging refrigerant additionally when refrigerant gas leaks, the refrigerant composition in the refrigerating cycle changes resulted in change of air conditioner characteristics or refrigerant over the specified standard amount is charged and an abnormal high pressure is applied to the inside of the refrigerating cycle resulted in cause of breakage or injury. Therefore if the refrigerant gas leaks, recover the refrigerant in the air conditioner, execute vacuuming, and then newly recharge the specified amount of liquid refrigerant. In this time, never charge the refrigerant over the specified amount.</p>
	<p>When recharging the refrigerant in the refrigerating cycle, do not mix the refrigerant or air other than R410A into the specified refrigerant. If air or others is mixed with the refrigerant, abnormal high pressure generates in the refrigerating cycle resulted in cause of injury due to breakage.</p>
	<p>After the installation work, confirm that refrigerant gas does not leak. If refrigerant gas leaks into the room and flows near a fire source, such as a cooking range, noxious gas may be generated.</p>
 Assembly/ Cabling	<p>Never recover the refrigerant into the outdoor unit. When the equipment is moved or repaired, be sure to recover the refrigerant with recovering device. The refrigerant cannot be recovered in the outdoor unit; otherwise a serious accident such as breakage or injury is caused.</p>
 Assembly/ Cabling	<p>After repair work, surely assemble the disassembled parts, and connect and lead the removed wires as before. Perform the work so that the cabinet or panel does not catch the inner wires. If incorrect assembly or incorrect wire connection was done, a disaster such as a leak or fire is caused at user's side.</p>
 Insulator check	<p>After the work has finished, be sure to use an insulation tester set (500V Megger) to check the resistance is 1MΩ or more between the charge section and the non-charge metal section (Earth position). If the resistance value is low, a disaster such as a leak or electric shock is caused at user's side.</p>
 Ventilation	<p>When the refrigerant gas leaks during work, execute ventilation. If the refrigerant gas touches to a fire, poisonous gas generates. A case of leakage of the refrigerant and the closed room full with gas is dangerous because a shortage of oxygen occurs. Be sure to execute ventilation.</p>
	<p>If refrigerant gas has leaked during the installation work, ventilate the room immediately. If the leaked refrigerant gas comes in contact with fire, noxious gas may be generated.</p>
 Compulsion	<p>After the installation work, confirm that refrigerant gas does not leak. If refrigerant gas leaks into the room and flows near a fire source, such as a cooking range, noxious gas may be generated.</p>
	<p>When the refrigerant gas leaks, find up the leaked position and repair it surely. If the leaked position cannot be found up and the repair work is interrupted, pump-down and tighten the service valve, otherwise the refrigerant gas may leak into the room. The poisonous gas generates when gas touches to fire such as fan heater, stove or cooking stove though the refrigerant gas itself is innocuous. When installing equipment which includes a large amount of charged refrigerant such as a multi air conditioner in a sub-room, it is necessary that the density does not the limit even if the refrigerant leaks. If the refrigerant leaks and exceeds the limit density, an accident of shortage of oxygen is caused.</p>
	<p>Tighten the flare nut with a torque wrench in the specified manner. Excessive tighten of the flare nut may cause a crack in the flare nut after a long period, which may result in refrigerant leakage.</p>
	<p>Nitrogen gas must be used for the airtight test.</p>
	<p>The charge hose must be connected in such a way that it is not slack.</p>
	<p>For the installation/moving/reinstallation work, follow to the Installation Manual. If an incorrect installation is done, a trouble of the refrigerating cycle, water leak, electric shock or fire is caused.</p>

 Check after repair	Once the repair work has been completed, check for refrigerant leaks, and check the insulation resistance and water drainage. Then perform a trial run to check that the air conditioner is running properly.
	After repair work has finished, check there is no trouble. If check is not executed, a fire, electric shock or injury may be caused. For a check, turn off the power breaker.
	After repair work (installation of front panel and cabinet) has finished, execute a test run to check there is no generation of smoke or abnormal sound. If check is not executed, a fire or an electric shock is caused. Before test run, install the front panel and cabinet.
 Do not operate the unit with the valve closed.	Check the following matters before a test run after repairing piping. <ul style="list-style-type: none"> • Connect the pipes surely and there is no leak of refrigerant. • The valve is opened. Running the compressor under condition that the valve closes causes an abnormal high pressure resulted in damage of the parts of the compressor and etc. and moreover if there is leak of refrigerant at connecting section of pipes, the air is suctioned and causes further abnormal high pressure resulted in burst or injury.
 Check after reinstallation	Only a qualified installer (*1) or qualified service person (*1) is allowed to relocate the air conditioner. It is dangerous for the air conditioner to be relocated by an unqualified individual since a fire, electric shocks, injury, water leakage, noise and/or vibration may result.
	Check the following items after reinstallation. <ol style="list-style-type: none"> 1) The earth wire is correctly connected. 2) The power cord is not caught in the product. 3) There is no inclination or unsteadiness and the installation is stable. If check is not executed, a fire, an electric shock or an injury is caused.
 Cooling check	When carrying out the pump-down work shut down the compressor before disconnecting the refrigerant pipe. Disconnecting the refrigerant pipe with the service valve left open and the compressor still operating will cause air, etc. to be sucked in, raising the pressure inside the refrigeration cycle to an abnormally high level, and possibly resulting in reputing, injury, etc.
	When the service panel of the outdoor unit is to be opened in order for the compressor or the area around this part to be repaired immediately after the air conditioner has been shut down, set the circuit breaker to the OFF position, and then wait at least 10 minutes before opening the service panel. If you fail to heed this warning, you will run the risk of burning yourself because the compressor pipes and other parts will be very hot to the touch. In addition, before proceeding with the repair work, wear the heat-resistant gloves.
 Installation	When the service panel of the outdoor unit is to be opened in order for the fan motor, reactor, inverter or the areas around these parts to be repaired immediately after the air conditioner has been shut down, set the circuit breaker to the OFF position, and then wait at least 10 minutes before opening the service panel. If you fail to heed this warning, you will run the risk of burning yourself because the fan motor, reactor, inverter heat sink and other parts will be very hot to the touch. In addition, before proceeding with the repair work, wear the heat-resistant gloves.
	Only a qualified installer (*1) or qualified service person (*1) is allowed to install the air conditioner. If the air conditioner is installed by an unqualified individual, a fire, electric shocks, injury, water leakage, noise and/or vibration may result.
	Before starting to install the air conditioner, read carefully through the Installation Manual, and follow its instructions to install the air conditioner.
	Do not install the air conditioner in a location that may be subject to a risk of expire to a combustible gas. If a combustible gas leaks and becomes concentrated around the unit, a fire may occur.
	Install a circuit breaker that meets the specifications in the installation manual and the stipulations in the local regulations and laws. Install the circuit breaker where it can be easily accessed by the agent.
	Do not place any combustion appliance in a place where it is directly exposed to the wind of air conditioner, otherwise it may cause imperfect combustion.

Explanations given to user

- If you have discovered that the fan grille is damaged, do not approach the outdoor unit but set the circuit breaker to the OFF position, and contact a qualified service person to have the repairs done.
Do not set the circuit breaker to the ON position until the repairs are completed.

Relocation

- Only a qualified installer (*1) or qualified service person (*1) is allowed to relocate the air conditioner. It is dangerous for the air conditioner to be relocated by an unqualified individual since a fire, electric shocks, injury, water leakage, noise and/or vibration may result.
- When carrying out the pump-down work shut down the compressor before disconnecting the refrigerant pipe. Disconnecting the refrigerant pipe with the service valve left open and the compressor still operating will cause air, etc. to be sucked in, raising the pressure inside the refrigeration cycle to an abnormally high level, and possibly resulting in reputing, injury, etc.

(*1) Refer to the “Definition of Qualified Installer or Qualified Service Person.”

Declaration of Conformity

Manufacturer: TOSHIBA CARRIER (THAILAND) CO., LTD.
144 / 9 Moo 5, Bangkadi Industrial Park, Tivanon Road,
Amphur Muang, Pathumthani 12000, Thailand

Authorized Nick Ball

Representative/TCF holder: Toshiba EMEA Engineering Director
Toshiba Carrier UK Ltd.
Porsham Close, Belliver Industrial Estate,
PLYMOUTH, Devon, PL6 7DB.
United Kingdom

Hereby declares that the machinery described below:

Generic Denomination: Air Conditioner

Model/type: RAV-SP404ATP-E RAV-SP454ATP-E RAV-SP564ATP-E
RAV-SP564ATJP-E RAV-SP804ATP-E RAV-SP804ATJP-E

Commercial name: Super Digital Inverter Series Air Conditioner

Complies with the provisions of the “Machinery” Directive (Directive 2006/42/EC) and the regulations transposing into national law.

Complies with the provisions of the following harmonized standard:

EN 378-2: 2008 + A2:2012

Note: This declaration becomes invalid if technical or operational modifications are introduced without the manufacturer’s consent.

Disposal

How to dispose of air conditioners with a rating of 12 kW and below in accordance with the 2002/96/EC Directive WEEE (Waste Electrical and Electronic Equipment) is provided in the Installation Manual supplied with your product. For disposal of the product above 12 kW in rating you should use a registered company in accordance with any national or EU legislation.

<Model names with a rating of 12 kW and below (outdoor units)>

SDI series

RAV-SP404ATP-E RAV-SP454ATP-E RAV-SP564ATP-E
RAV-SP564ATJP-E RAV-SP804ATP-E RAV-SP804ATJP-E

Specifications

Model	Sound power level (dBA)		Weight (kg)
	Cooling	Heating	
RAV-SP404ATP-E	*	*	40
RAV-SP454ATP-E	*	*	40
RAV-SP564ATP-E	*	*	44
RAV-SP564ATJP-E	*	*	44
RAV-SP804ATP-E	*	*	66
RAV-SP804ATJP-E	*	*	66

* Under 70 dBA

• New Refrigerant (R410A)

This air conditioner adopts a new HFC type refrigerant (R410A) which does not deplete the ozone layer.

1. Safety Caution Concerned to New Refrigerant

The pressure of R410A is high 1.6 times of that of the former refrigerant (R22).

Accompanied with change of refrigerant, the refrigerating oil has been also changed.

Therefore, be sure that water, dust, the former refrigerant or the former refrigerating oil is not mixed into the refrigerating cycle of the air conditioner with new refrigerant during installation work or service work.

If an incorrect work or incorrect service is performed, there is a possibility to cause a serious accident.

Use the tools and materials exclusive to R410A to purpose a safe work.

2. Cautions on Installation/Service

1) Do not mix the other refrigerant or refrigerating oil.

For the tools exclusive to R410A, shapes of all the joints including the service port differ from those of the former refrigerant in order to prevent mixture of them.

2) As the use pressure of the new refrigerant is high, use material thickness of the pipe and tools which are specified for R410A.

3) In the installation time, use clean pipe materials and work with great attention so that water and others do not mix in because pipes are affected by impurities such as water, oxide scales, oil, etc.

Use the clean pipes.

Be sure to brazing with flowing nitrogen gas. (Never use gas other than nitrogen gas.)

4) For the earth protection, use a vacuum pump for air purge.

5) R410A refrigerant is azeotropic mixture type refrigerant.

Therefore use liquid type to charge the refrigerant. (If using gas for charging, composition of the refrigerant changes and then characteristics of the air conditioner change.)

3. Pipe Materials

For the refrigerant pipes, copper pipe and joints are mainly used.

It is necessary to select the most appropriate pipes to conform to the standard.

Use clean material in which impurities adhere inside of pipe or joint to a minimum.

1) Copper pipe

<Piping>

The pipe thickness, flare finishing size, flare nut and others differ according to a refrigerant type.

When using a long copper pipe for R410A, it is recommended to select "Copper or copper-base pipe without seam" and one with bonded oil amount 40mg/10m or less.

Also do not use crushed, deformed, discolored (especially inside) pipes. (Impurities cause clogging of expansion valves and capillary tubes.)

<Flare nut>

Use the flare nuts which are attached to the air conditioner unit.

2) Joint

The flare joint and socket joint are used for joints of the copper pipe.

The joints are rarely used for installation of the air conditioner. However clear impurities when using them.

4. Tools

1. Required Tools for R410A

Mixing of different types of oil may cause a trouble such as generation of sludge, clogging of capillary, etc. Accordingly, the tools to be used are classified into the following three types.

- 1) Tools exclusive for R410A (Those which cannot be used for conventional refrigerant (R22))
- 2) Tools exclusive for R410A, but can be also used for conventional refrigerant (R22)
- 3) Tools commonly used for R410A and for conventional refrigerant (R22)

The table below shows the tools exclusive for R410A and their interchangeability.

Tools exclusive for R410A (The following tools for R410A are required.)

Tools whose specifications are changed for R410A and their interchangeability

No.	Used tool	Usage	R410A air conditioner installation		Conventional air conditioner installation
			Existence of new equipment for R410A	Whether conventional equipment can be used	Whether conventional equipment can be used
①	Flare tool	Pipe flaring	Yes	*(Note)	Yes
②	Copper pipe gauge for adjusting projection margin	Flaring by conventional flare tool	Yes	*(Note)	*(Note)
③	Torque wrench	Tightening of flare nut	Yes	No	No
④	Gauge manifold	Evacuating, refrigerant charge, run check, etc.	Yes	No	No
⑤	Charge hose				
⑥	Vacuum pump adapter	Vacuum evacuating	Yes	No	Yes
⑦	Electronic balance for refrigerant charging	Refrigerant charge	Yes	Yes	Yes
⑧	Leakage detector	Gas leakage check	Yes	No	Yes

(Note) When flaring is carried out for R410A using the conventional flare tools, adjustment of projection margin is necessary. For this adjustment, a copper pipe gauge, etc. are necessary.

General tools (Conventional tools can be used.)

In addition to the above exclusive tools, the following equipments which serve also for R22 are necessary as the general tools.

- | | |
|-------------------------------------------------------------------|----------------------------------------|
| 1) Vacuum pump. Use vacuum pump by attaching vacuum pump adapter. | 7) Screwdriver (+, -) |
| 2) Torque wrench | 8) Spanner or Monkey wrench |
| 3) Pipe cutter | 9) Hole core drill |
| 4) Reamer | 10) Hexagon wrench (Opposite side 4mm) |
| 5) Pipe bender | 11) Tape measure |
| 6) Level vial | 12) Metal saw |

Also prepare the following equipments for other installation method and run check.

- | | |
|----------------|------------------------------------------|
| 1) Clamp meter | 3) Insulation resistance tester (Megger) |
| 2) Thermometer | 4) Electroscopes |

1. SPECIFICATIONS

1-1. Outdoor Unit

<Super Digital Inverter>

Model name	Outdoor unit	RAV-SP	404ATP*	454ATP*	564ATP*	804ATP*	
Power supply		1 phase 220-240V 50Hz (Power exclusive to outdoor is required.)					
Compressor	Type	Hermetic compressor					
	Motor	(kW)	1.1	1.1	1.1	1.1	
	Pole		4	4	4	4	
Refrigerant charged		(kg)	1.0	1.0	1.4	2.1	
Refrigerant control		Pulse motor valve					
Inter connecting pipe	Standard length		(m)	7.5	7.5	7.5	7.5
	Min. length		(m)	5	5	5	5
	Max. total length		(m)	30	30	50	50
	Additional refrigerant charge under long piping connector			20g/m (21m to 30m)	20g/m (21m to 30m)	40g/m (21m to 50m)	40g/m (31m to 50m)
	Height difference	Outdoor lower	(m)	30	30	30	30
		Outdoor higher	(m)	30	30	30	30
Outer dimension	Height		(mm)	550	550	550	890
	Width		(mm)	780	780	780	900
	Depth		(mm)	290	290	290	320
Appearance		Silky shade (Muncel 1Y8.5/0.5)					
Total weight		(kg)	40	40	44	66	
Heat exchanger		Finned tube					
Fan unit	Fan		Propeller fan				
	Standard air flow high		(m ³ /min.)	40	40	40	50
	Motor		(W)	43	43	43	63
Connecting pipe	Gas side		(mm)	12.7	12.7	12.7	15.9
	Liquid side		(mm)	6.4	6.4	6.4	9.5
Sound pressure level		Cooling/Heating (dB-A)	45/47	45/47	47/48	48/49	
Sound power level		Cooling/Heating (dB-A)	62/64	62/64	63/64	64/65	
Outside air temperature, Cooling		(°C)	43 to -15				
Outside air temperature, Heating		(°C)	15 to -15		15 to -20		

1-2. Operation Characteristic Curve

RAV-SP40*ATP*, SP45*ATP*

<Cooling>

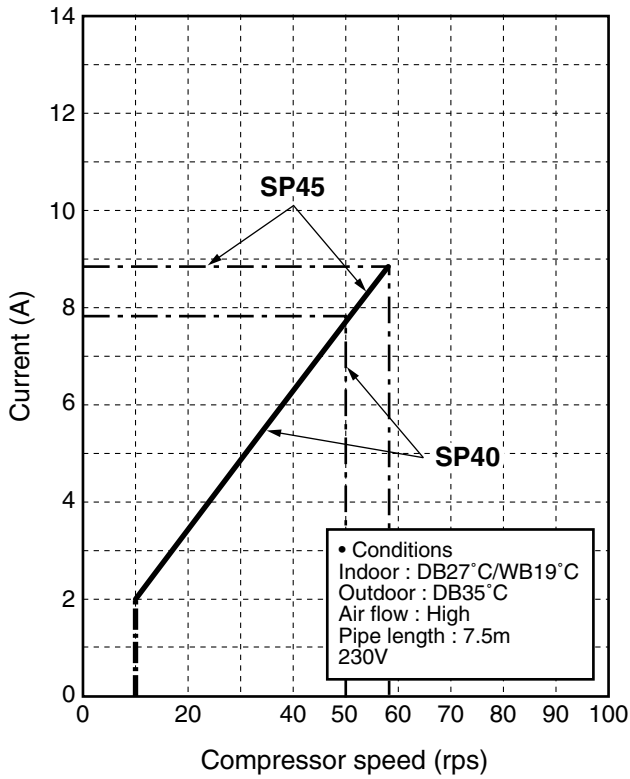

<Heating>

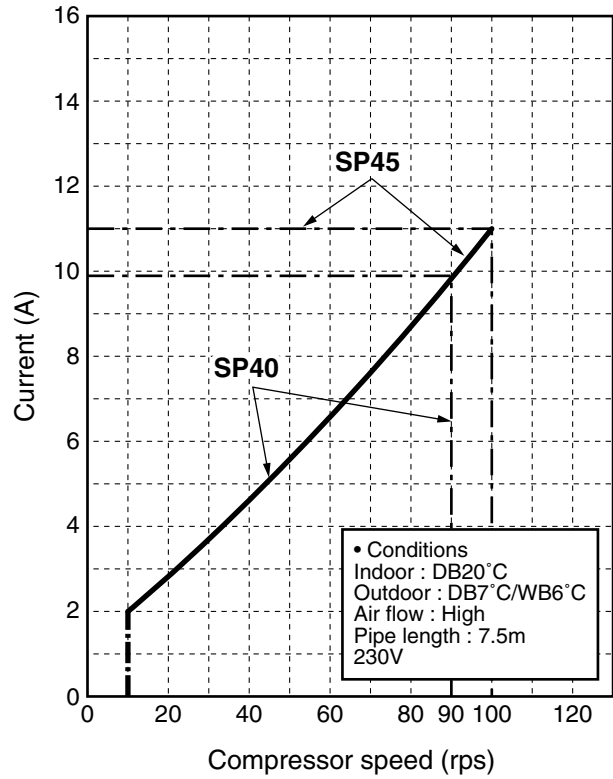

RAV-SP56*ATP*

<Cooling>

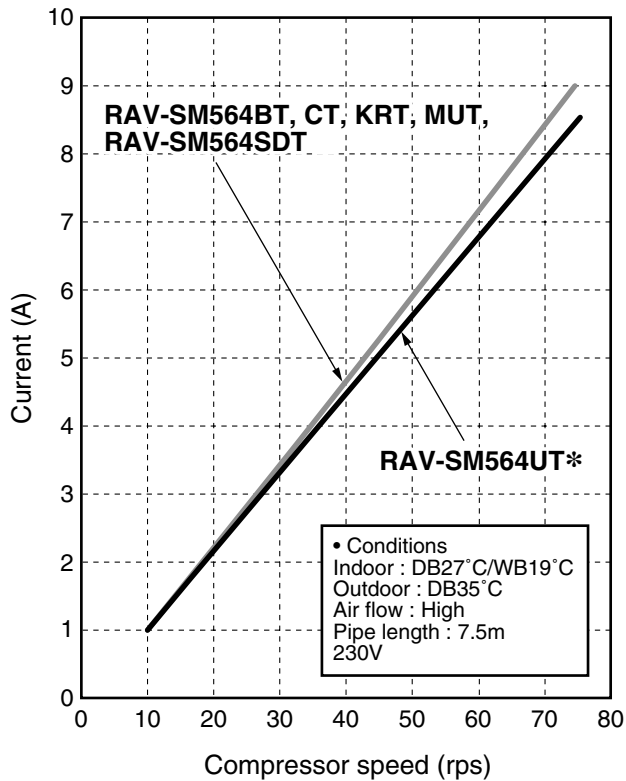

<Heating>

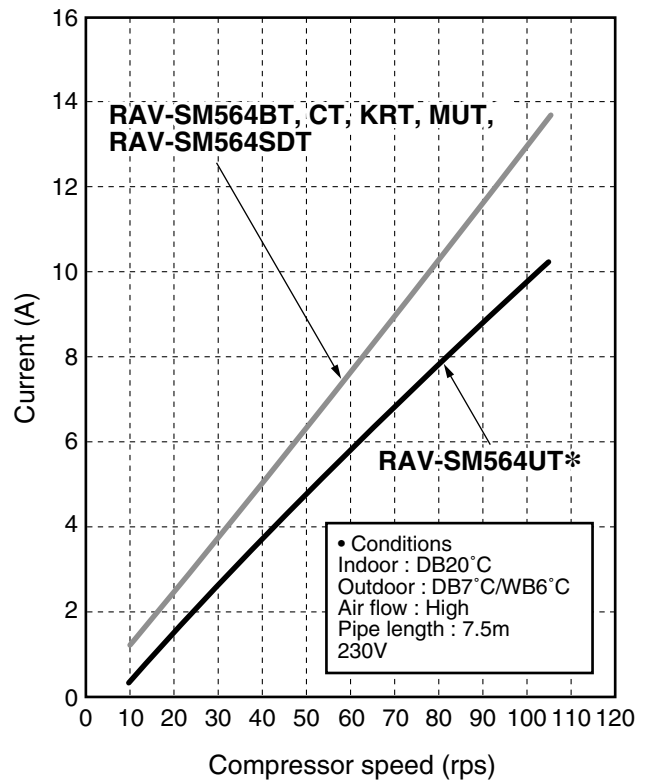

RAV-SP80*ATP*

<Cooling>

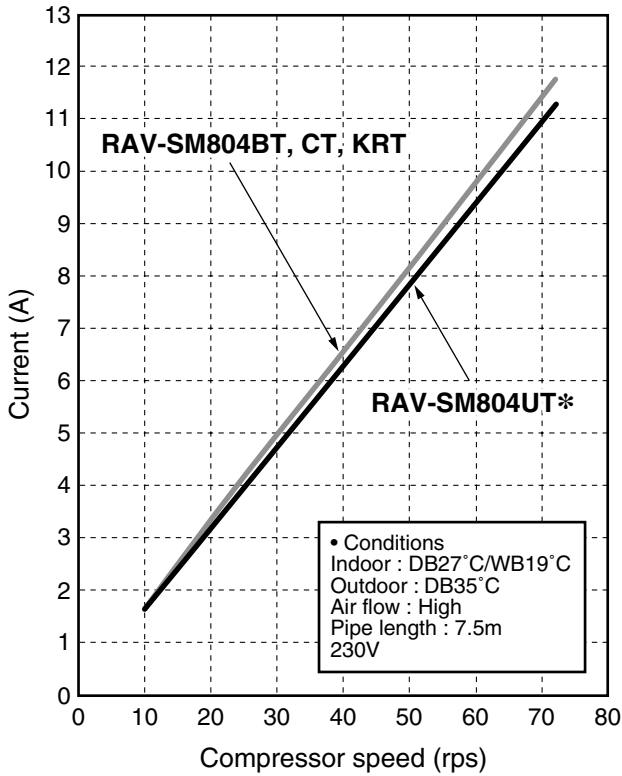

<Heating>

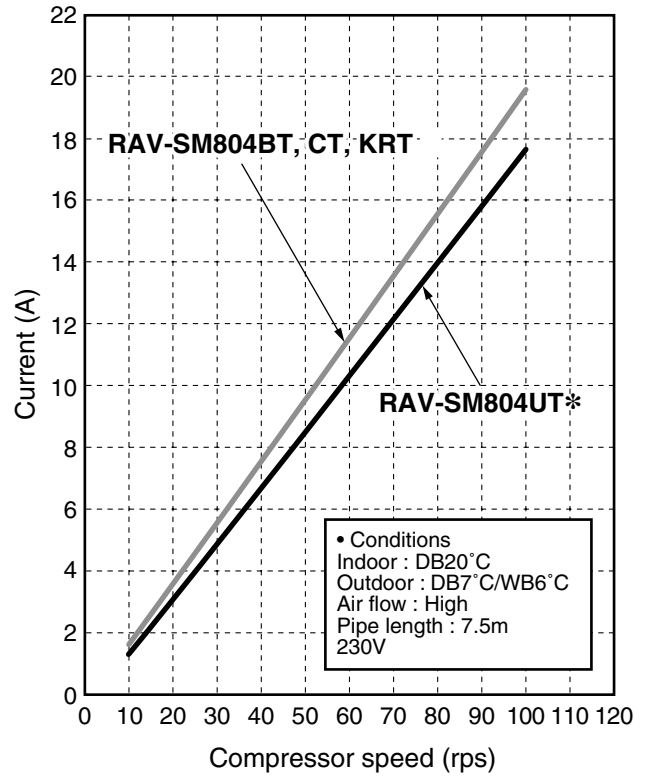

• Capacity variation ratio according to temperature

RAV-SP40*ATP*, SP45*ATP*
RAV-SP56*ATP*, RAV-SP80*ATP*

<Cooling>

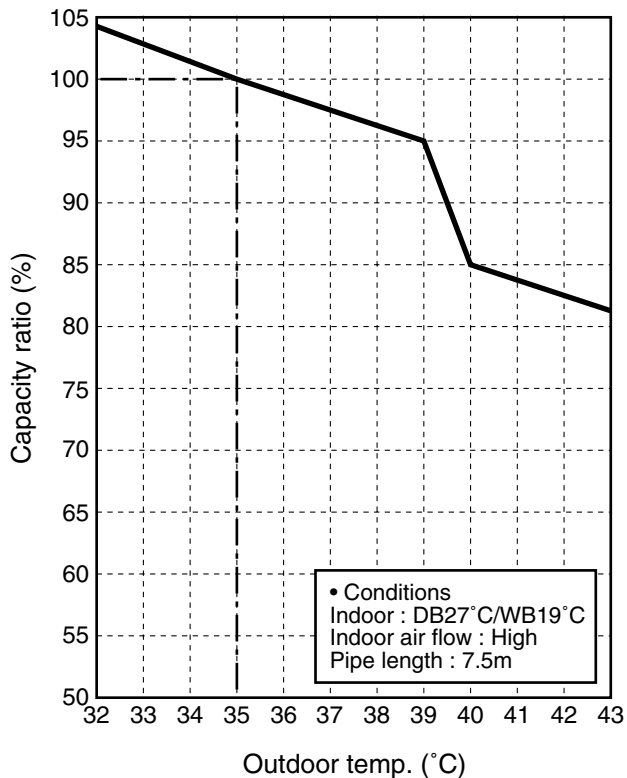

<Heating>

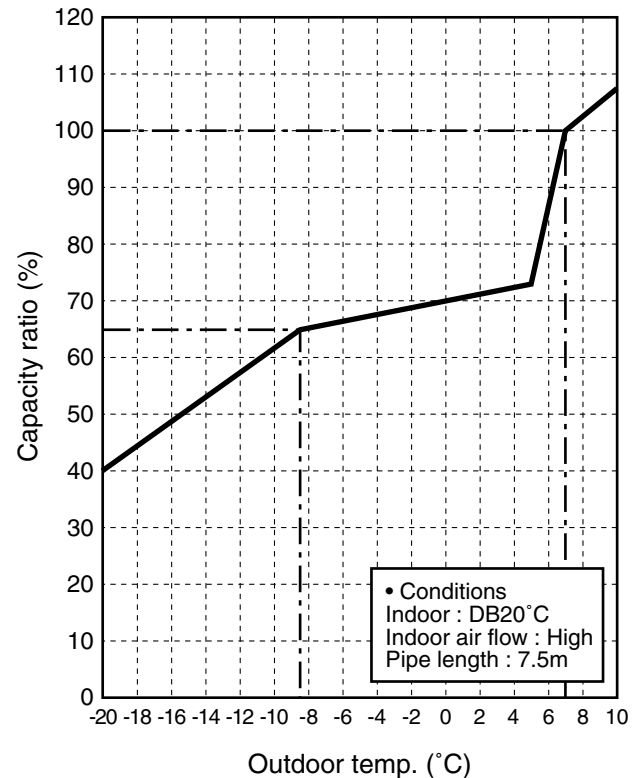

2. CONSTRUCTION VIEWS (EXTERNAL VIEWS)

2-1. RAV-SP40*ATP*, SP45*ATP*, SP56*ATP*

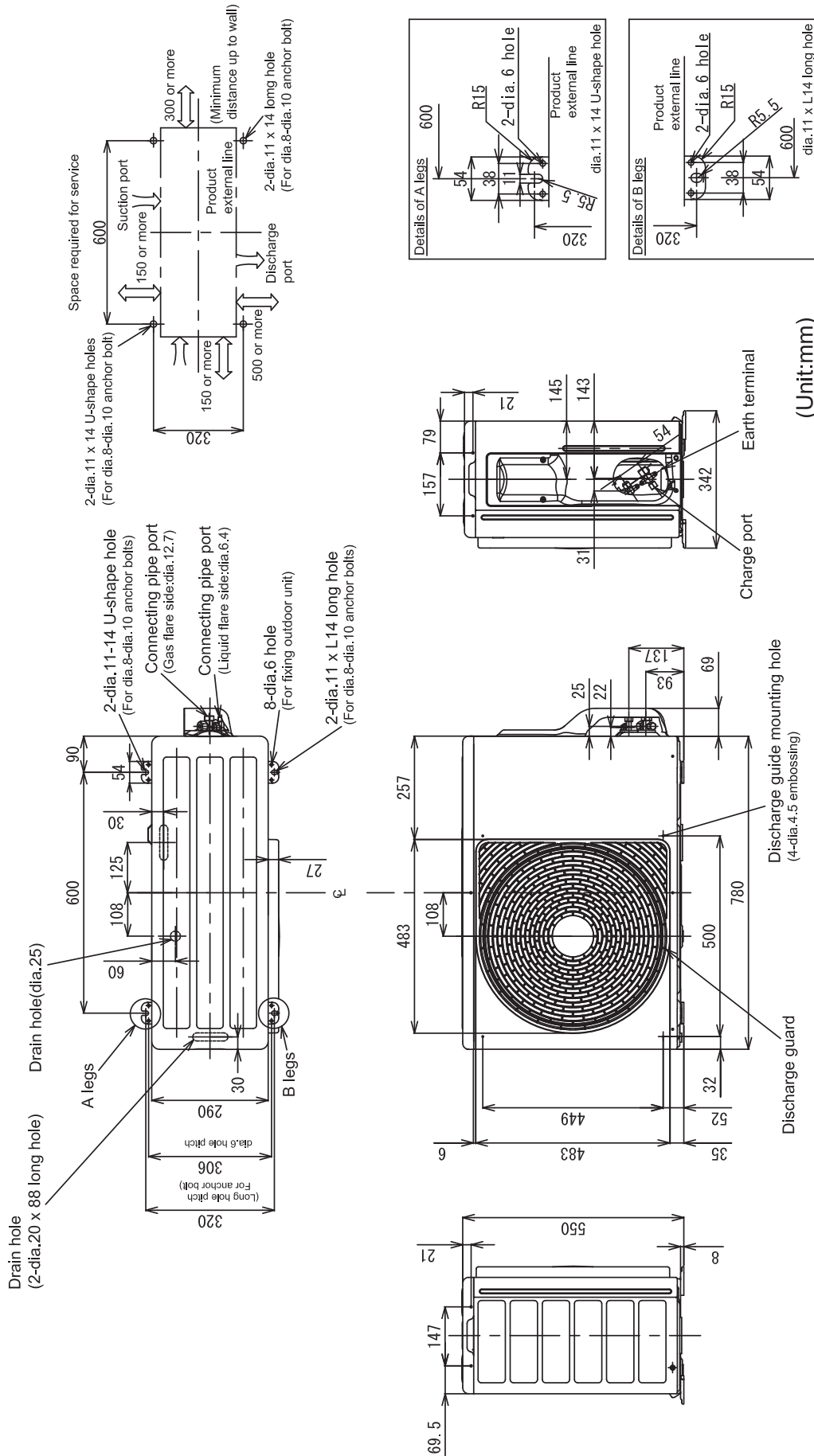

(Unit:mm)

2-2. RAV-SP80*ATP*

	Name	Note
①	Refrigerant piping hole Indoor/Outdoor Unit connecting wire inlet hole	—
②	Power supply inlet hole	dia. 38 Knockout hole

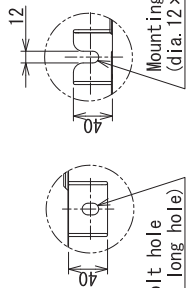

Details of A legs
Details of B legs

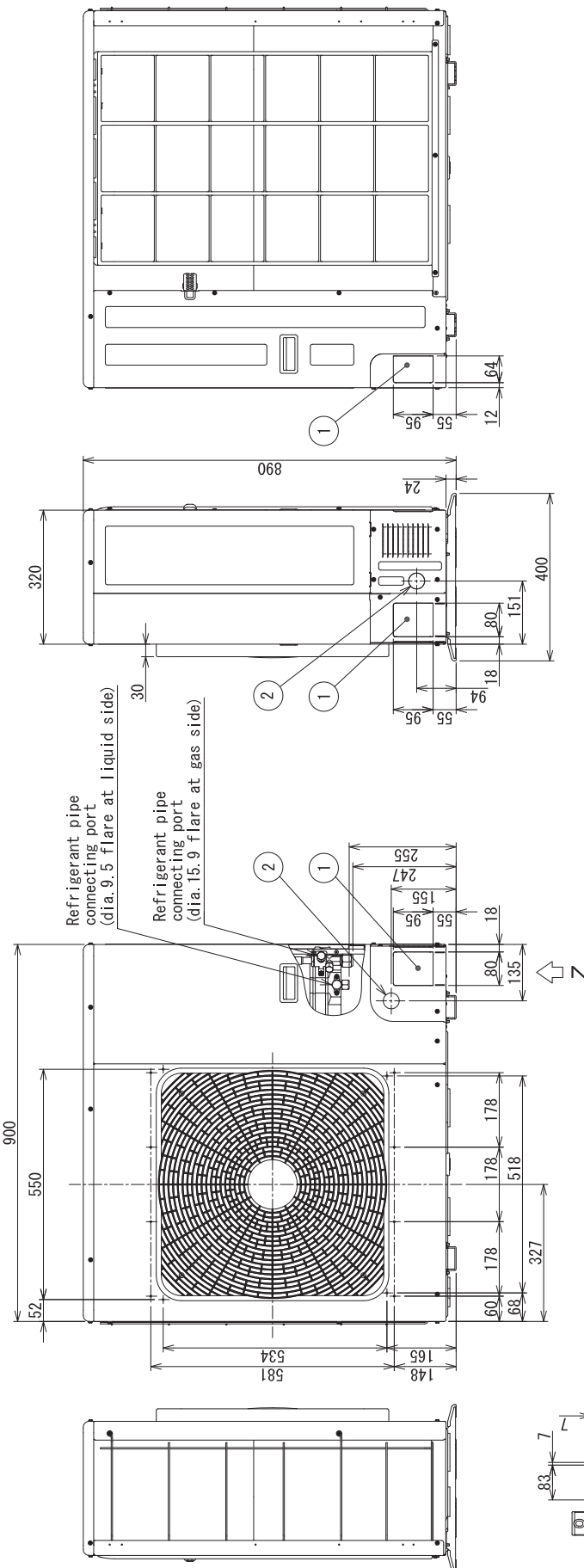
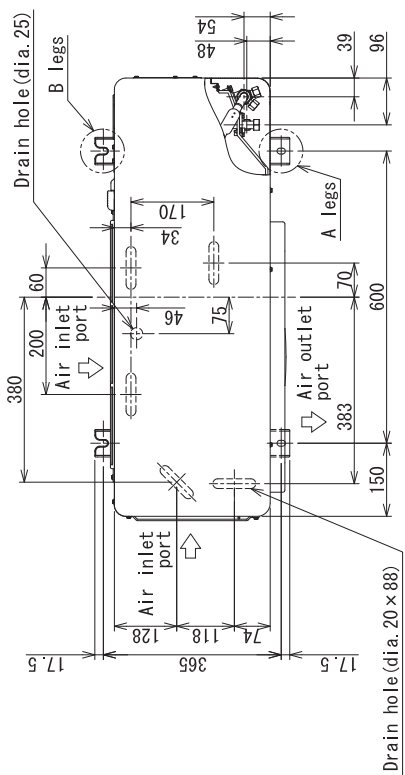

Z views

(Unit:mm)

RAV-TWP30E2, RAV-TWP50E2 (Simultaneous Twin)

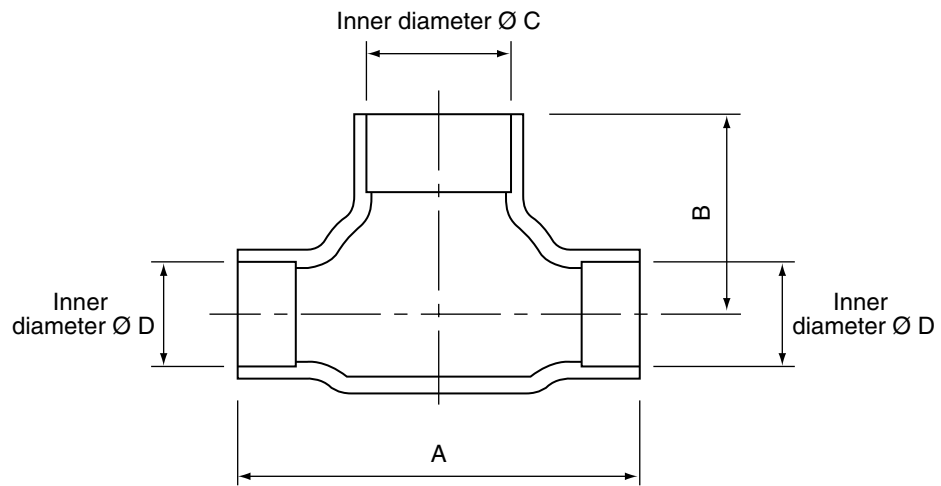

Model (RBC-)		A	B	C	D
TWP30E2	Liquid side	36	14	Ø9.5	Ø6.4
	Gas side	43	23	Ø15.9	Ø12.7
TWP50E2	Liquid side	34	14	Ø9.5	Ø9.5
	Gas side	44	21	Ø15.9	Ø15.9

3. SYSTEMATIC REFRIGERATING CYCLE DIAGRAM

3-1. Indoor Unit

- Single type (Combination of 1 indoor unit and 1 outdoor unit)

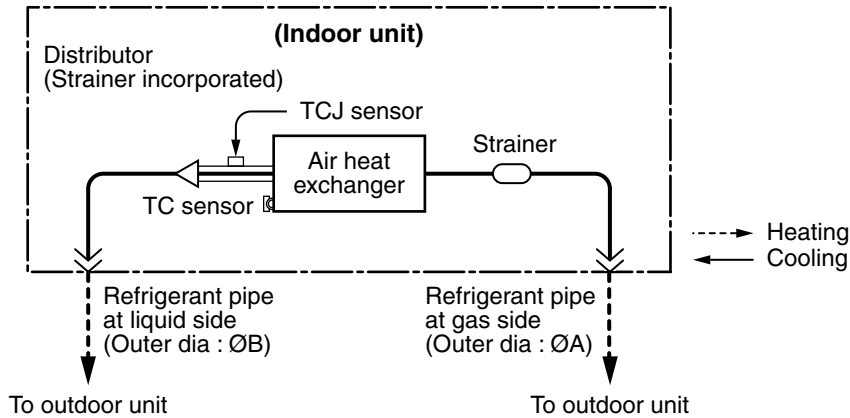

Dimension table

Indoor unit	Outer diameter of refrigerant pipe	
	Gas side ØA	Liquid side ØB
SM40, 45, 56 type	12.7	6.4
SM80 type	15.9	9.5

- Twin type (Combination of 2 indoor units and 1 outdoor unit)

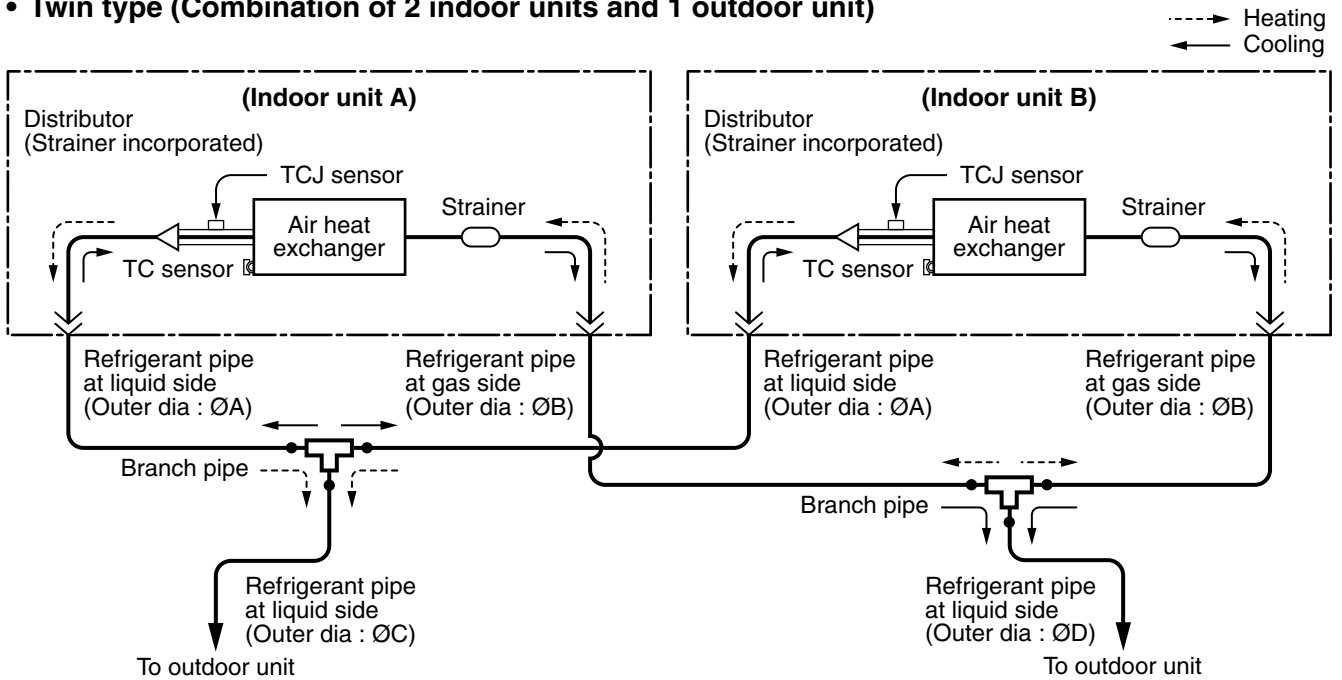

Indoor unit	Branch pipe RBC-	A	B	C	D
SM40 × 2	TWP30E2	6.4	12.7	9.5	15.9

3-2.Outdoor Unit

RAV-SP40*ATP*, SP45*ATP*

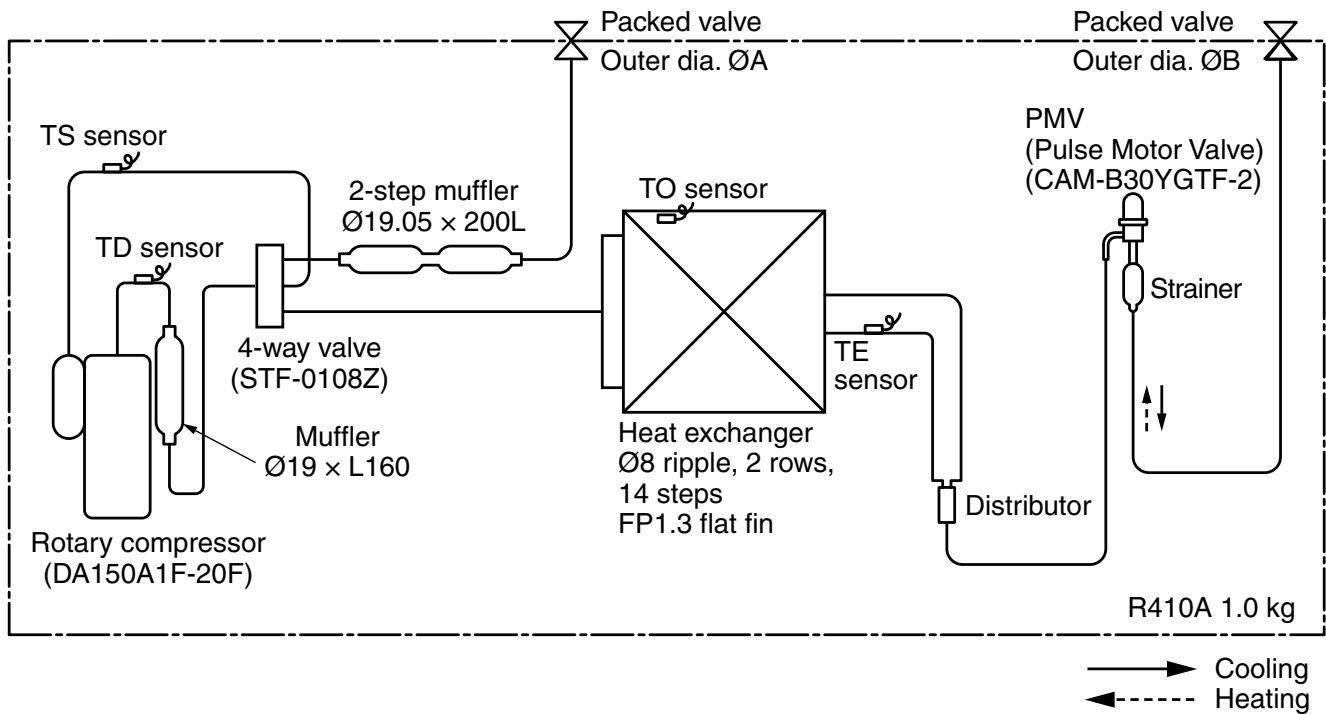

RAV-SP40*ATP*

		Pressure				Pipe surface temperature (°C)				Compressor drive revolution frequency (rps)	Indoor fan	Indoor/Outdoor temp. conditions (DB/WB) (°C)	
		(MPa)		(kg/cm ² g)		Discharge	Suction	Indoor heat exchanger	Outdoor heat exchanger			Indoor	Outdoor
		Pd	Ps	Pd	Ps	(TD)	(TS)	(TC)	(TE)				
Cooling	Standard	2.68	0.94	27.3	9.6	61	12	11	43	47	HIGH	27 / 19	35 / -
	Overload	3.23	1.16	32.9	11.8	77	14	15	50	50	HIGH	32 / 24	43 / -
	Low load	1.34	0.70	13.7	7.1	36	4	2	8	44	LOW	18 / 15.5	-5 / -
Heating	Standard	2.38	0.70	24.3	7.1	65	7	39	4	49	HIGH	20 / -	7 / 6
	Overload	3.39	1.03	34.6	10.5	83	20	54	16	49	LOW	30 / -	24 / 18
	Low load	1.95	0.26	19.9	2.7	90	-17	32	-19	90	HIGH	15 / -	-15 / -

* This compressor has 4-pole motor. The value when compressor frequency (Hz) is measured by a clamp meter becomes 2 times of No. of compressor revolutions (rps).

RAV-SP45*ATP*

		Pressure				Pipe surface temperature (°C)				Compressor drive revolution frequency (rps)	Indoor fan	Indoor/Outdoor temp. conditions (DB/WB) (°C)	
		(MPa)		(kg/cm ² g)		Discharge	Suction	Indoor heat exchanger	Outdoor heat exchanger			Indoor	Outdoor
		Pd	Ps	Pd	Ps	(TD)	(TS)	(TC)	(TE)				
Cooling	Standard	2.81	0.89	28.7	9.1	68	11	10	41	53	HIGH	27 / 19	35 / -
	Overload	3.24	1.16	33.0	11.8	78	14	15	51	53	HIGH	32 / 24	43 / -
	Low load	1.34	0.70	13.7	7.1	36	4	2	8	44	LOW	18 / 15.5	-5 / -
Heating	Standard	2.53	0.68	25.8	6.9	70	7	41	4	56	HIGH	20 / -	7 / 6
	Overload	3.39	1.03	34.6	10.5	83	20	54	16	49	LOW	30 / -	24 / 18
	Low load	2.00	0.25	20.4	2.6	92	-17	33	-19	98	HIGH	15 / -	-15 / -

* This compressor has 4-pole motor. The value when compressor frequency (Hz) is measured by a clamp meter becomes two times of No. of compressor revolutions (rps).

RAV-SP56*ATP*

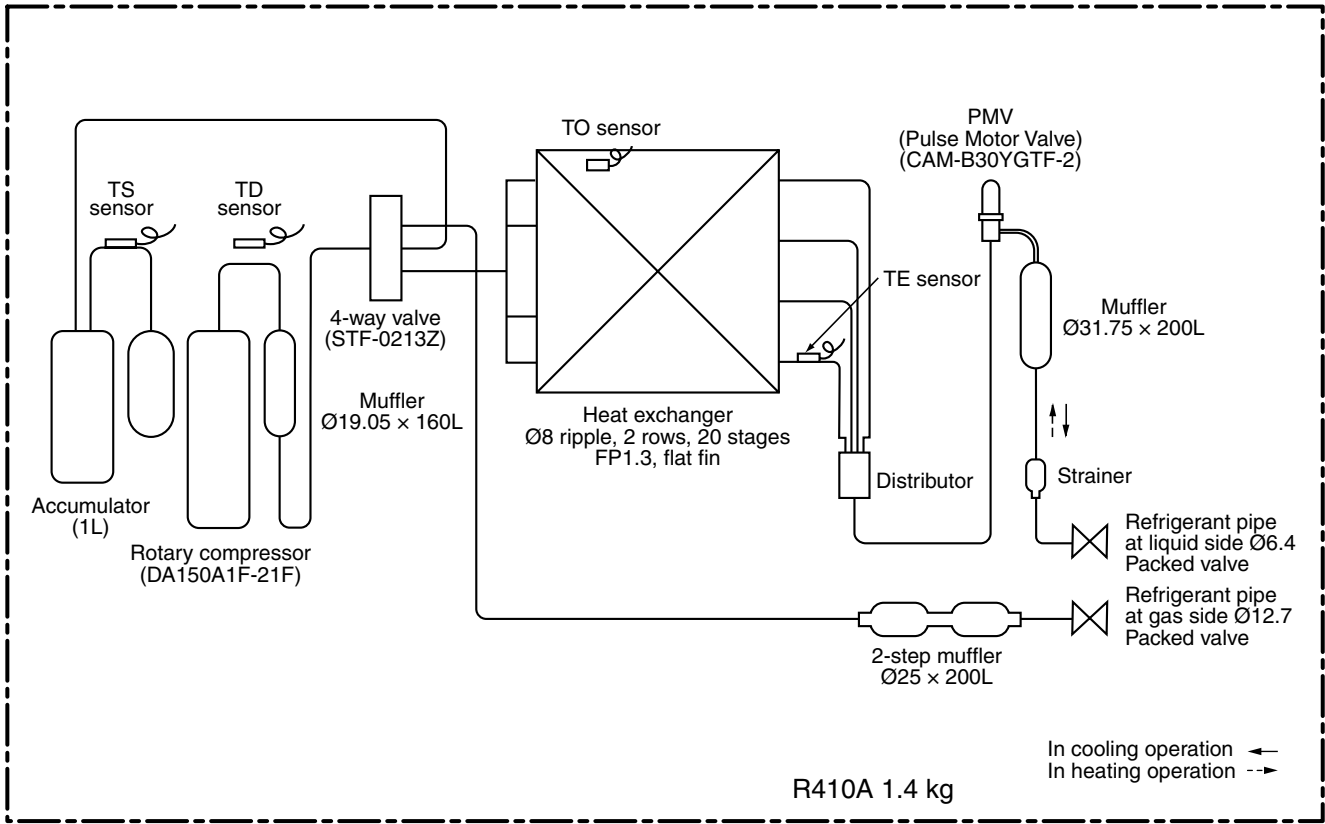

		Pressure				Pipe surface temperature (°C)				Compressor drive revolution frequency (rps)	Indoor fan	Indoor/Outdoor temp. conditions (DB/WB) (°C)	
		(MPa)		(kg/cm ² g)		Discharge	Suction	Indoor heat exchanger	Outdoor heat exchanger			Indoor	Outdoor
		Pd	Ps	Pd	Ps	(TD)	(TS)	(TC)	(TE)				
Cooling	Standard	2.87	1.00	29.3	10.2	72	16	13	42	58	HIGH	27 / 19	35 / -
	Overload	3.57	1.10	36.4	11.2	88	20	19	52	76	HIGH	32 / 24	43 / -
	Low load	1.71	0.76	17.4	7.8	45	12	7	13	30	LOW	18 / 15.5	-5 / -
Heating	Standard	2.26	0.68	23.1	6.9	66	6	37	3	64	HIGH	20 / -	7 / 6
	Overload	3.25	1.14	33.2	11.6	78	20	53	16	30	LOW	30 / -	24 / 18
	Low load	2.00	0.25	20.4	2.6	78	-18	34	-18	88	HIGH	15 / -	-15 / -

RAV-SP80*ATP*

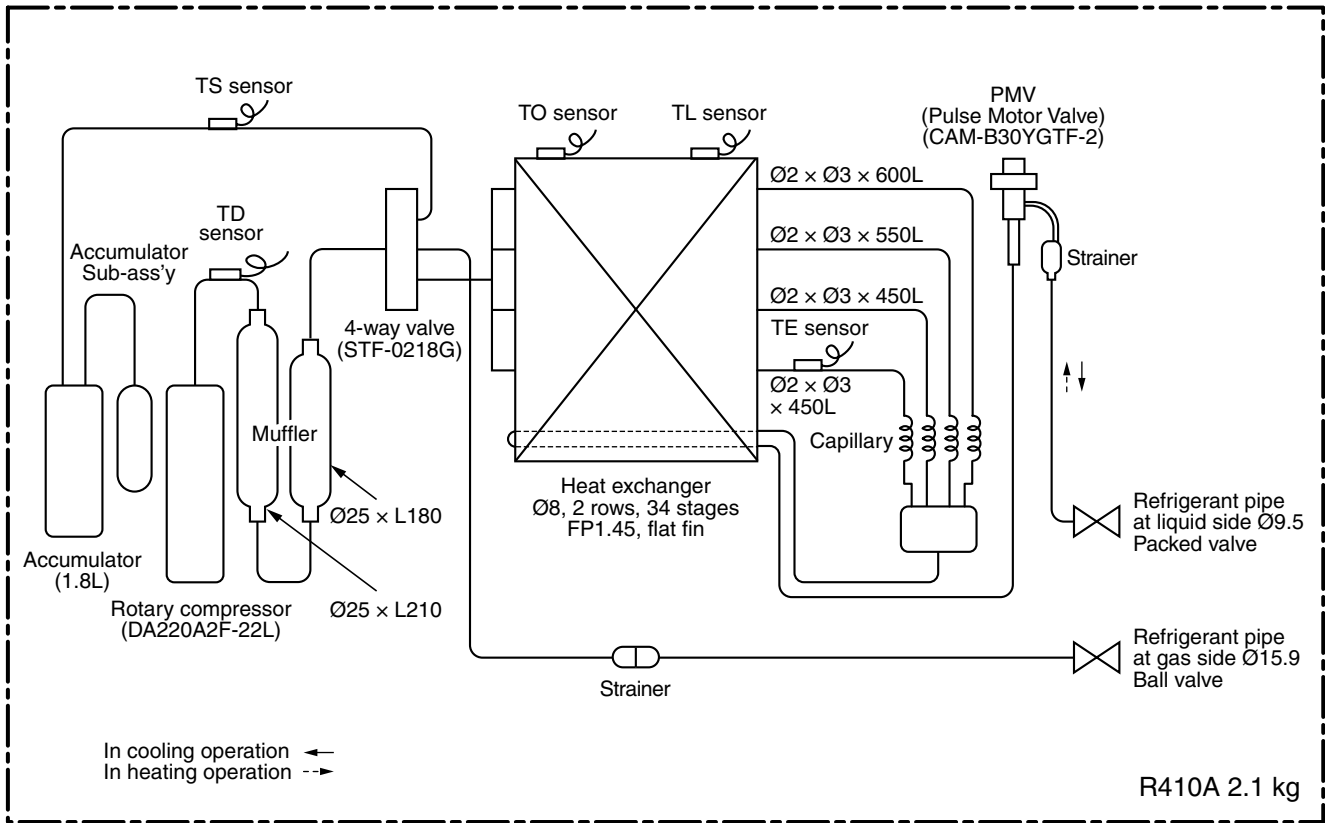

		Pressure				Pipe surface temperature (°C)				Compressor drive revolution frequency (rps)	Indoor fan	Indoor/Outdoor temp. conditions (DB/WB) (°C)	
		(MPa)		(kg/cm ² g)		Discharge	Suction	Indoor heat exchanger	Outdoor heat exchanger			Indoor	Outdoor
		Pd	Ps	Pd	Ps	(TD)	(TS)	(TC)	(TE)				
Cooling	Standard	2.79	0.89	27.3	8.7	70	13	11	39	58.2	HIGH	27 / 19	35 / -
	Overload	3.53	1.07	34.6	10.5	81	17	14	48	65	HIGH	32 / 24	43 / -
	Low load	1.71	0.72	16.8	7.1	42	7	3	18	30	LOW	18 / 15.5	-15 / -
Heating	Standard	2.65	0.68	26.0	6.7	74	4	44	3	61.5	HIGH	20 / -	7 / 6
	Overload	3.2	1.11	31.4	10.9	76	19	52	15	28	LOW	30 / -	24 / 18
	Low load	2.33	0.21	22.8	2.1	93	-18	31	-20	99.6	HIGH	15 / -	-20 / -

4. WIRING DIAGRAM

4-1. RAV-SP40*ATP*, SP45*ATP*, SP56*ATP*

The 4-way valve coil is turned on while the cooling operation

Color Identification

BLK	: BLACK	WHI	: WHITE
BLU	: BLUE	ORN	: ORANGE
RED	: RED	YEL	: YELLOW
GRN	: GREEN		

Symbol	parts name
49C	Compressor case thermostat
4WV	4-way valve coil
CM	Compressor
FM	Fan motor
F01	Fuse T25A 250V~
F04	Fuse T6.3A 250V~
OPTION	Optional P.C. Board
PMV	Pulse motor valve
TD	Discharge pipe temp. sensor
TE	Condenser pipe temp. sensor
T0	Outdoor temp. sensor
TS	Suction pipe temp. sensor
TB1	Terminal block

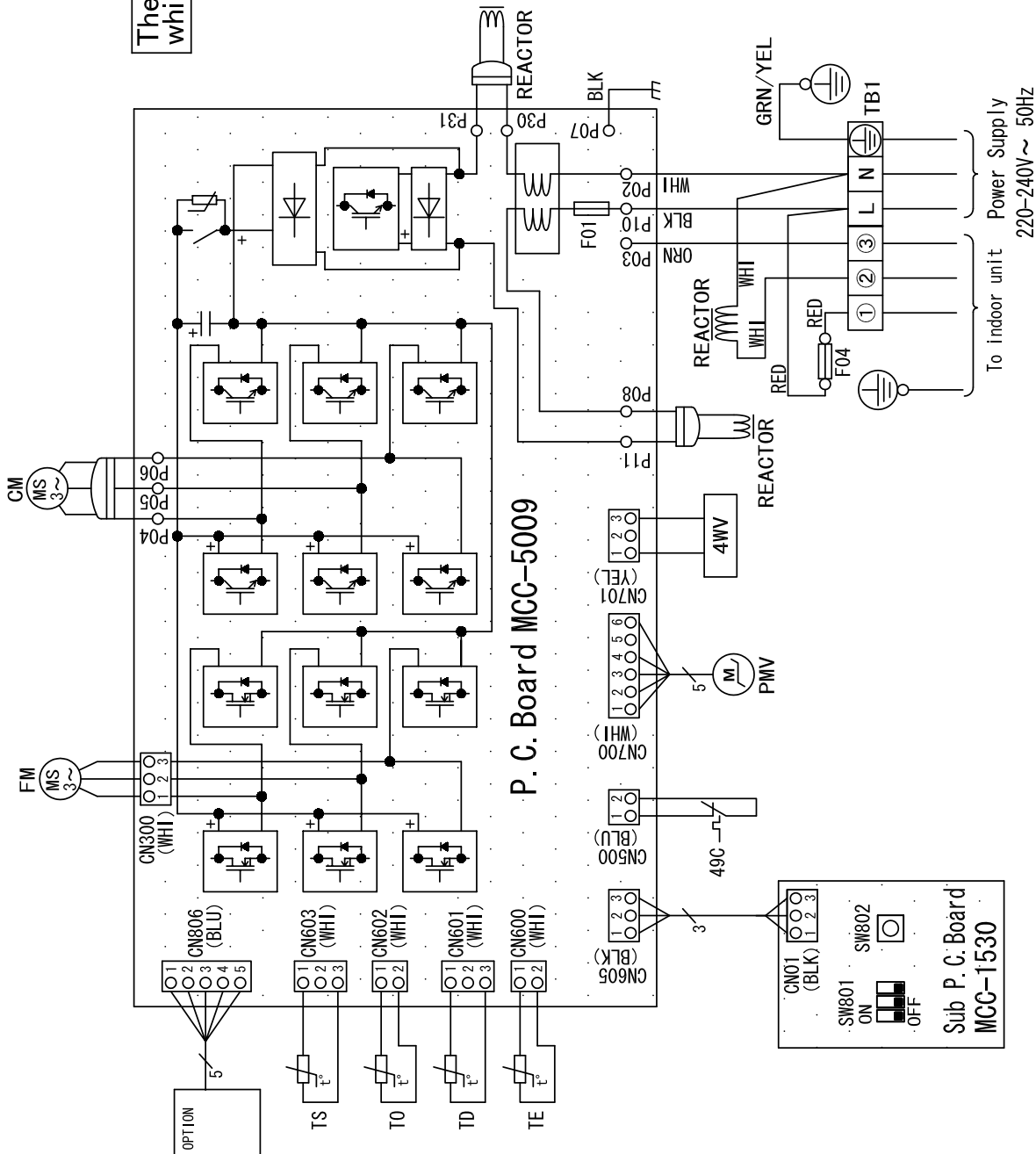

4-2. RAV-SP80*ATP

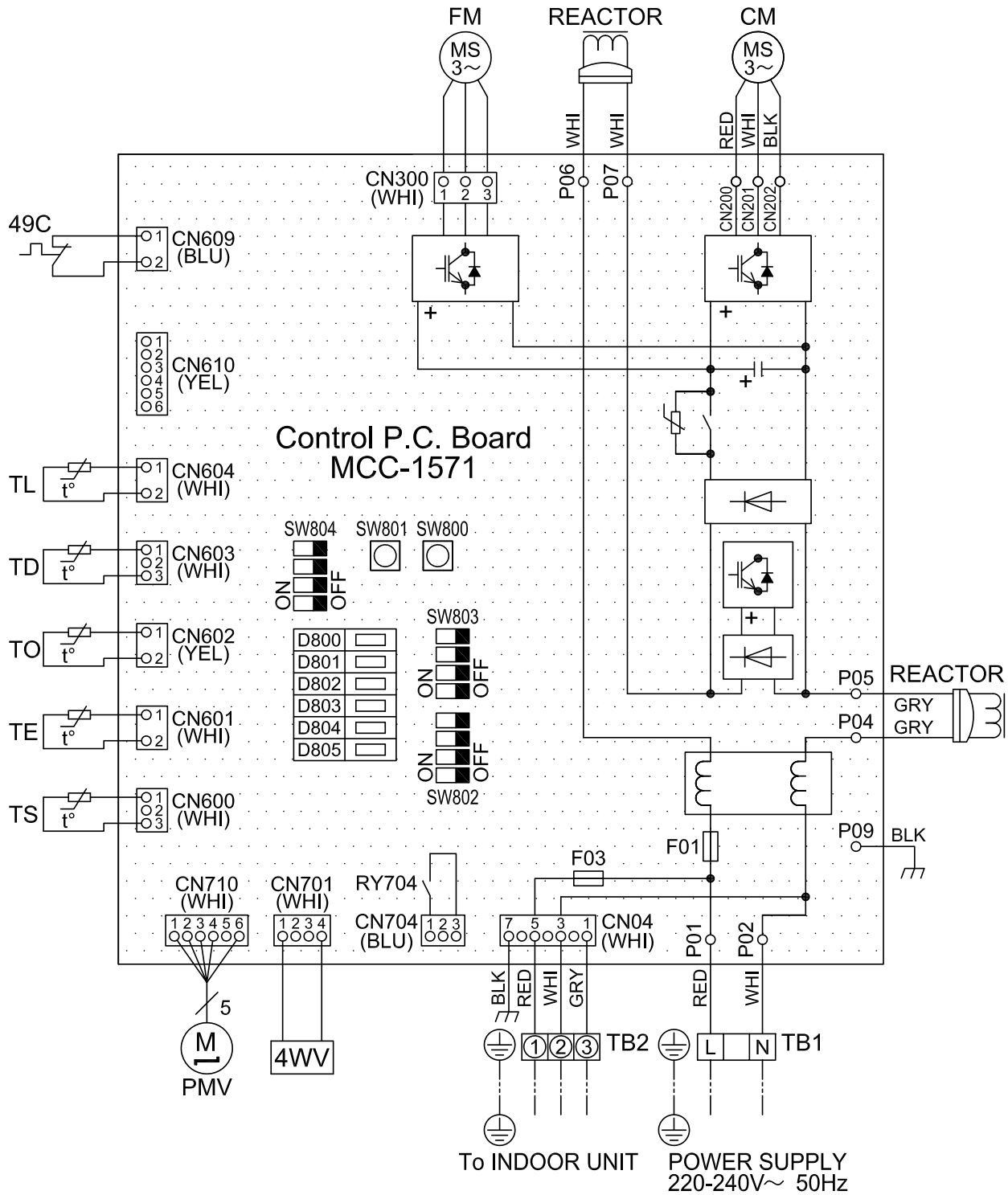

Symbol	Parts name	Symbol	Parts name
49C	Compressor case thermostat	PMV	Pulse motor valve
4WV	4-way valve coil	TD	Pipe temp. sensor (discharge)
CM	Compressor	TE	Heat exchange temp. sensor 1
FM	Fan motor	TL	Heat exchange temp. sensor 2
F01	Fuse 25A 250V~ (for main power supply)	TO	Outside temp. sensor
F03	Fuse T10A 250V~ (for indoor unit)	TS	Pipe temp. sensor (suction)
REACTOR	Reactor	TB1	Terminal block (power supply)
		TB2	Terminal block (to indoor unit)

---	Field wiring
⊕	Protective earth
□	Terminal block
○	Terminal
○ ○	Connector
⋯	P.C.board

Color Indication

BLK : BLACK
 BLU : BLUE
 GRY : GRAY
 RED : RED
 YEL : YELLOW
 WHI : WHITE

5. SPECIFICATIONS OF ELECTRICAL PARTS

RAV-SP40*ATP*, SP45*ATP*, SP56*ATP*

No.	Parts name	Type	Specifications
1	Compressor	40, 45 : DA150A1F-20F 56 : DA150A1F-21F	3 phase, 4P, 1100 W
2	Fan motor	ICF-140-43-4R	Output 43 W
3	4-way valve coil	STF-H01AJ1872A1	-
4	PMV coil	CAM-MD12TCTH-5	-
5	P.C. board	MCC-5009	-
6	Reactor	CH-57	10mH, 16A
7	Fuse (Switching power (Protect))	-	T3.15A, AC 250V
8	Fuse (Inverter, input (Current protect))	-	AC240V
9	Outdoor temp. sensor (To sensor)	-	10 kΩ at 25°C
10	Heat exchanger sensor (Te sensor)	-	10 kΩ at 25°C
11	Suction temp. sensor (Ts sensor)	-	10 kΩ at 25°C
12	Discharge temp. sensor (Td sensor)	-	50 kΩ at 25°C
13	Compressor thermo. (Protection)	CS-12AL	OFF: 125 ± 4°C, ON: 90 ± 5°C

RAV-SP80*ATP*

No.	Parts name	Type	Specifications
1	Compressor	DA220A2F-22L	
2	Fan motor	ICF-280-A60-1	Output 60 W
3	4-way valve coil	STF-H01AP1874A	-
4	PMV coil	CAM-MD12TCTH-6	-
5	P.C. board	MCC-1571	-
6	Reactor	CH-56	5.8 mH, 18.5 A
7	Fuse (Mounted on P.C. board)	-	AC250 V, 25 A
8	Fuse (Mounted on P.C. board)	-	AC250 V, 10 A
9	Fuse (Mounted on P.C. board)	-	AC250 V, 3.15 A
10	Outdoor temp. sensor (To sensor)	-	10 kΩ at 25°C
11	Heat exchanger sensor (Te sensor)	-	10 kΩ at 25°C
12	Suction temp. sensor (Ts sensor)	-	10 kΩ at 25°C
13	Discharge temp. sensor (Td sensor)	-	50 kΩ at 25°C
14	Heat exchanger temp. sensor (TI sensor)	-	50 kΩ at 25°C
15	Compressor thermo. (Protection)	CS-12AL	OFF: 125 ± 4°C, ON: 90 ± 5°C

6. REFRIGERANT R410A

This air conditioner adopts the new refrigerant HFC (R410A) which does not damage the ozone layer.

The working pressure of the new refrigerant R410A is 1.6 times higher than conventional refrigerant (R22). The refrigerating oil is also changed in accordance with change of refrigerant, so be careful that water, dust, and existing refrigerant or refrigerating oil are not entered in the refrigerant cycle of the air conditioner using the new refrigerant during installation work or servicing time.

The next section describes the precautions for air conditioner using the new refrigerant.

Conforming to contents of the next section together with the general cautions included in this manual, perform the correct and safe work.

6-1. Safety During Installation/Serviceing

As R410A's pressure is about 1.6 times higher than that of R22, improper installation/servicing may cause a serious trouble. By using tools and materials exclusive for R410A, it is necessary to carry out installation/servicing safely while taking the following precautions into consideration.

1. Never use refrigerant other than R410A in an air conditioner which is designed to operate with R410A.

If other refrigerant than R410A is mixed, pressure in the refrigeration cycle becomes abnormally high, and it may cause personal injury, etc. by a rupture.

2. Confirm the used refrigerant name, and use tools and materials exclusive for the refrigerant R410A.

The refrigerant name R410A is indicated on the visible place of the outdoor unit of the air conditioner using R410A as refrigerant.

To prevent mischarging, the diameter of the service port differs from that of R22.

3. If a refrigeration gas leakage occurs during installation/servicing, be sure to ventilate fully. If the refrigerant gas comes into contact with fire, a poisonous gas may occur.

4. When installing or removing an air conditioner, do not allow air or moisture to remain in the refrigeration cycle.

Otherwise, pressure in the refrigeration cycle may become abnormally high so that a rupture or personal injury may be caused.

5. After completion of installation work, check to make sure that there is no refrigeration gas leakage.

If the refrigerant gas leaks into the room, coming into contact with fire in the fan-driven heater, space heater, etc., a poisonous gas may occur.

6. When an air conditioning system charged with a large volume of refrigerant is installed in a small room, it is necessary to exercise care so that, even when refrigerant leaks, its concentration does not exceed the marginal level.

If the refrigerant gas leakage occurs and its concentration exceeds the marginal level, an oxygen starvation accident may result.

7. Be sure to carry out installation or removal according to the installation manual.

Improper installation may cause refrigeration trouble, water leakage, electric shock, fire, etc.

8. Unauthorized modifications to the air conditioner may be dangerous. If a breakdown occurs please call a qualified air conditioner technician or electrician.

Improper repair may result in water leakage, electric shock and fire, etc.

6-2. Refrigerant Piping Installation

6-2-1. Piping Materials and Joints Used

For the refrigerant piping installation, copper pipes and joints are mainly used.

Copper pipes and joints suitable for the refrigerant must be chosen and installed.

Furthermore, it is necessary to use clean copper pipes and joints whose interior surfaces are less affected by contaminants.

1. Copper Pipes

It is necessary to use seamless copper pipes which are made of either copper or copper alloy and it is desirable that the amount of residual oil is less than 40 mg/10 m.

Do not use copper pipes having a collapsed, deformed or discolored portion (especially on the interior surface).

Otherwise, the expansion valve or capillary tube may become blocked with contaminants.

As an air conditioner using R410A incurs pressure higher than when using R22, it is necessary to choose adequate materials.

Thicknesses of copper pipes used with R410A are as shown in Table 6-2-1. Never use copper pipes thinner than 0.8mm even when it is available on the market.

NOTE:

Refer to the "6-6. Instructions for Re-use Piping of R22 or R407C".

Table 6-2-1 Thicknesses of annealed copper pipes

		Thickness (mm)	
		R410A	R22
Nominal diameter	Outer diameter (mm)		
1/4	6.4	0.80	0.80
3/8	9.5	0.80	0.80
1/2	12.7	0.80	0.80
5/8	15.9	1.00	1.00

1. Joints

For copper pipes, flare joints or socket joints are used. Prior to use, be sure to remove all contaminants.

a) Flare Joints

Flare joints used to connect the copper pipes cannot be used for pipings whose outer diameter exceeds 20 mm. In such a case, socket joints can be used.

Sizes of flare pipe ends, flare joint ends and flare nuts are as shown in Tables 6-2-3 to 6-2-5 below.

b) Socket Joints

Socket joints are such that they are brazed for connections, and used mainly for thick pipings whose diameter is larger than 20 mm. Thicknesses of socket joints are as shown in Table 6-2-2.

Table 6-2-2 Minimum thicknesses of socket joints

Nominal diameter	Reference outer diameter of copper pipe jointed (mm)	Minimum joint thickness (mm)
1/4	6.4	0.50
3/8	9.5	0.60
1/2	12.7	0.70
5/8	15.9	0.80

6-2-2. Processing of Piping Materials

When performing the refrigerant piping installation, care should be taken to ensure that water or dust does not enter the pipe interior, that no other oil other than lubricating oils used in the installed air conditioner is used, and that refrigerant does not leak.

When using lubricating oils in the piping processing, use such lubricating oils whose water content has been removed. When stored, be sure to seal the container with an airtight cap or any other cover.

1. Flare Processing Procedures and Precautions

a) Cutting the Pipe

By means of a pipe cutter, slowly cut the pipe so that it is not deformed.

b) Removing Burrs and Chips

If the flared section has chips or burrs, refrigerant leakage may occur.

Carefully remove all burrs and clean the cut surface before installation.

- c) Insertion of Flare Nut
- d) Flare Processing

Make certain that a clamp bar and copper pipe have been cleaned.
 By means of the clamp bar, perform the flare processing correctly.
 Use either a flare tool for R410A or conventional flare tool.

Flare processing dimensions differ according to the type of flare tool.

When using a conventional flare tool, be sure to secure "dimension A" by using a gauge for size adjustment.

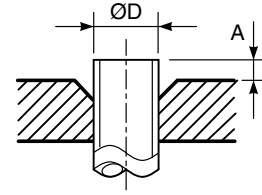

Fig. 6-2-1 Flare processing dimensions

Table 6-2-3 Dimensions related to flare processing for R410A / R22

Nominal diameter	Outer diameter (mm)	Thickness (mm)	A (mm)				
			Flare tool for R410A, R22 clutch type	Conventional flare tool (R410A)		Conventional flare tool (R22)	
				Clutch type	Wing nut type	Clutch type	Wing nut type
1/4	6.4	0.8	0 to 0.5	1.0 to 1.5	1.5 to 2.0	0.5 to 1.0	1.0 to 1.5
3/8	9.5	0.8	0 to 0.5	1.0 to 1.5	1.5 to 2.0	0.5 to 1.0	1.0 to 1.5
1/2	12.7	0.8	0 to 0.5	1.0 to 1.5	2.0 to 2.5	0.5 to 1.0	1.5 to 2.0
5/8	15.9	1.0	0 to 0.5	1.0 to 1.5	2.0 to 2.5	0.5 to 1.0	1.5 to 2.0

Table 6-2-4 Flare and flare nut dimensions for R410A

Nominal diameter	Outer diameter (mm)	Thickness (mm)	Dimension (mm)				Flare nut width (mm)
			A	B	C	D	
1/4	6.4	0.8	9.1	9.2	6.5	13	17
3/8	9.5	0.8	13.2	13.5	9.7	20	22
1/2	12.7	0.8	16.6	16.0	12.9	23	26
5/8	15.9	1.0	19.7	19.0	16.0	25	29

Table 6-2-5 Flare and flare nut dimensions for R22

Nominal diameter	Outer diameter (mm)	Thickness (mm)	Dimension (mm)				Flare nut width (mm)
			A	B	C	D	
1/4	6.4	0.8	9.1	9.2	6.5	13	17
3/8	9.5	0.8	13.0	13.5	9.7	20	22
1/2	12.7	0.8	16.2	16.0	12.9	20	24
5/8	15.9	1.0	19.4	19.0	16.0	23	27
3/4	19.0	1.0	23.3	24.0	19.2	34	36

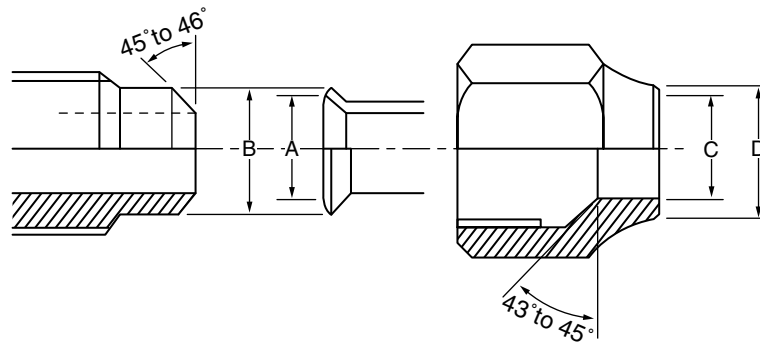

Fig. 6-2-2 Relations between flare nut and flare seal surface

2. Flare Connecting Procedures and Precautions

- a) Make sure that the flare and union portions do not have any scar or dust, etc.
- b) Correctly align the processed flare surface with the union axis.
- c) Tighten the flare with designated torque by means of a torque wrench.

The tightening torque for R410A is the same as that for conventional R22.

Incidentally, when the torque is weak, the gas leakage may occur.

When it is strong, the flare nut may crack and may be made non-removable.

When choosing the tightening torque, comply with values designated by manufacturers.

Table 6-2-6 shows reference values.

NOTE:

When applying oil to the flare surface, be sure to use oil designated by the manufacturer.

If any other oil is used, the lubricating oils may deteriorate and cause the compressor to burn out.

Table 6-2-6 Tightening torque of flare for R410A [Reference values]

Nominal diameter	Outer diameter (mm)	Tightening torque N•m (kgf•m)	Tightening torque of torque wrenches available on the market N•m (kgf•m)
1/4	6.4	14 to 18 (1.4 to 1.8)	16 (1.6), 18 (1.8)
3/8	9.5	33 to 42 (3.3 to 4.2)	42 (4.2)
1/2	12.7	50 to 62 (5.0 to 6.2)	55 (5.5)
5/8	15.9	63 to 77 (6.3 to 7.7)	65 (6.5)

6-3. Tools

6-3-1. Required Tools

Refer to the “4. Tools” (Page 13)

6-4. Recharging of Refrigerant

When it is necessary to recharge refrigerant, charge the specified amount of new refrigerant according to the following steps.

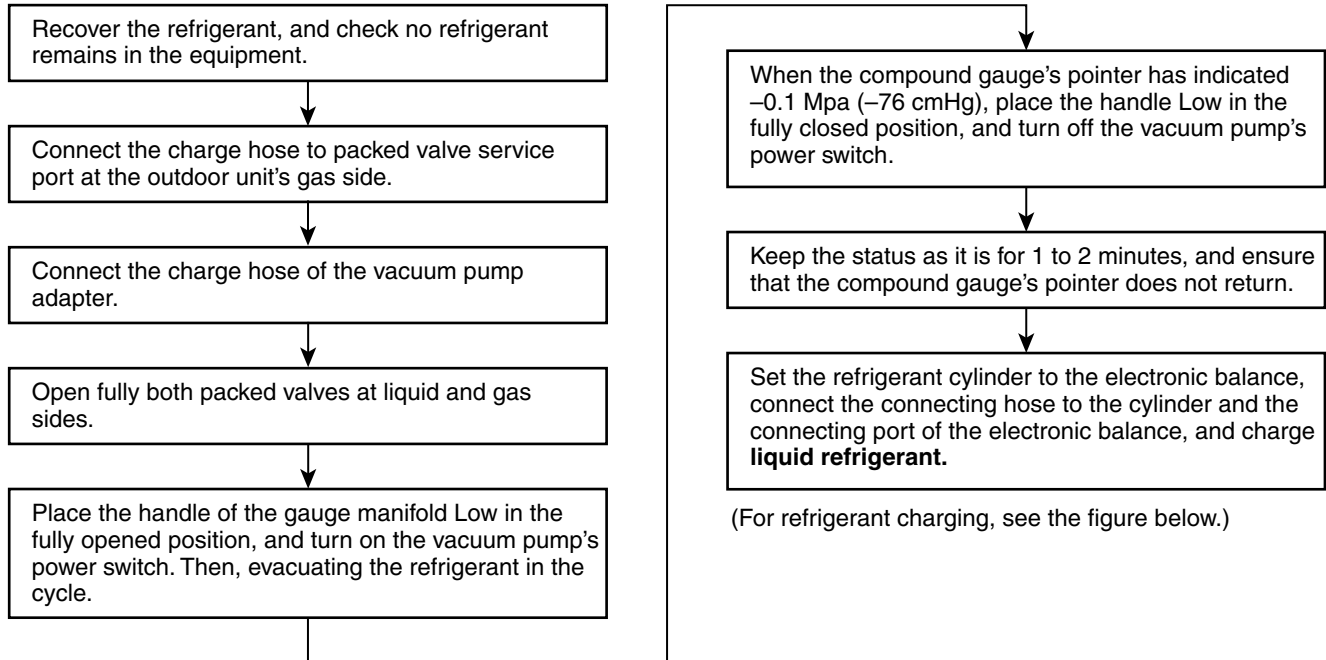

- 1) Never charge refrigerant exceeding the specified amount.
- 2) If the specified amount of refrigerant cannot be charged, charge refrigerant **bit by bit** in COOL mode.
- 3) Do not carry out additional charging.

When additional charging is carried out if refrigerant leaks, the refrigerant composition changes in the refrigeration cycle, that is characteristics of the air conditioner changes, refrigerant exceeding the specified amount is charged, and working pressure in the refrigeration cycle becomes abnormally high pressure, and may cause a rupture or personal injury.

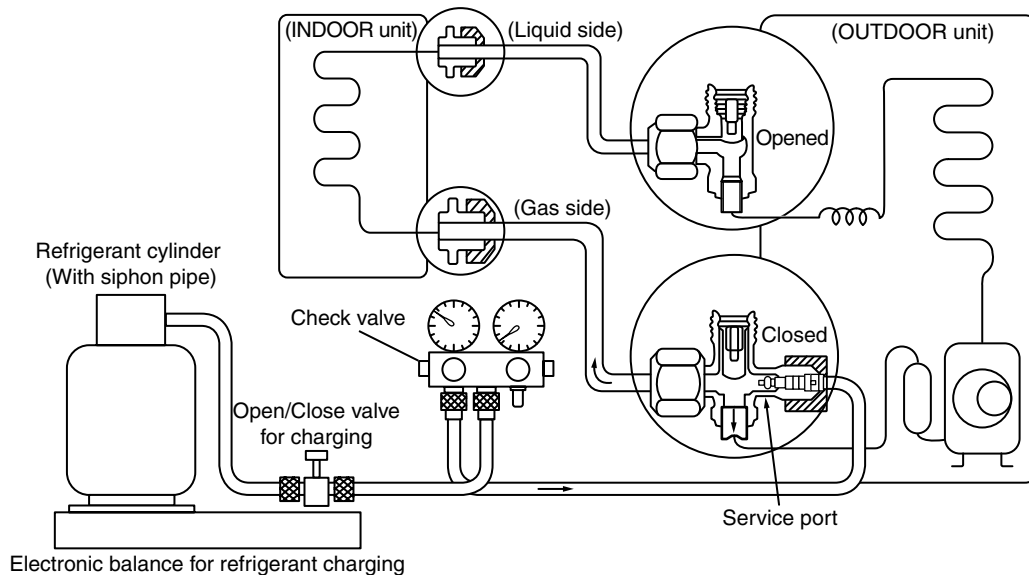
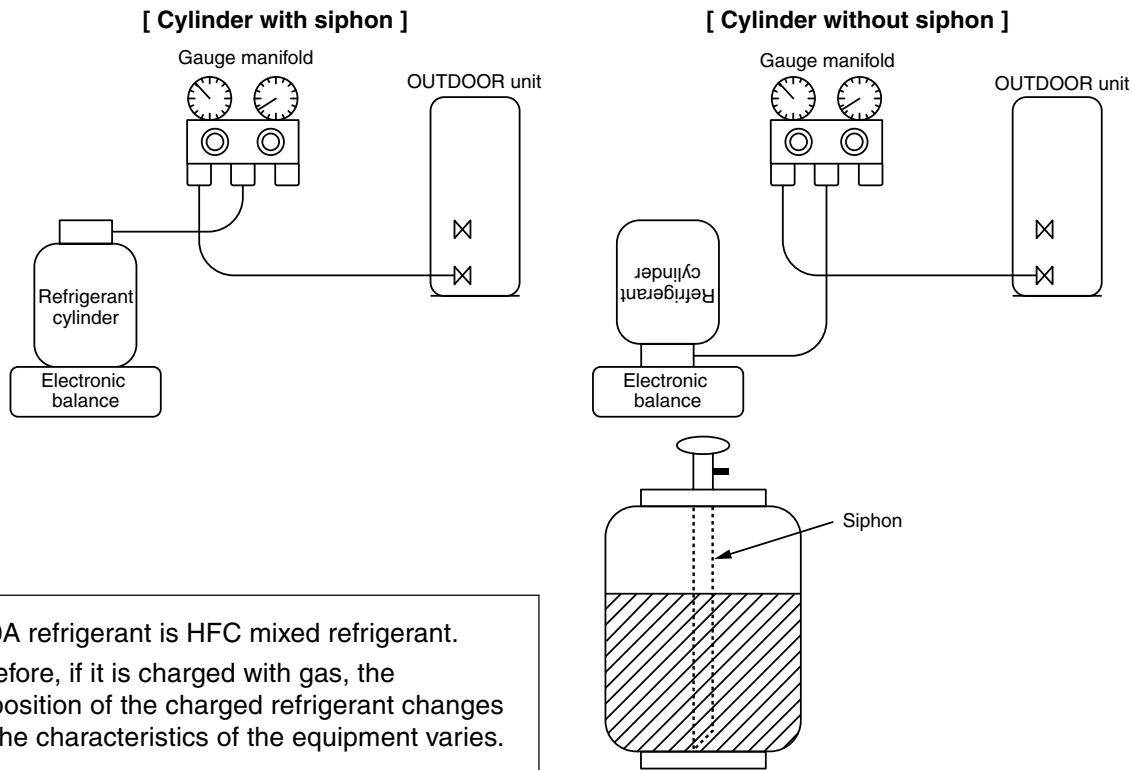

Fig. 6-4-1 Configuration of refrigerant charging

- 1) Be sure to make setting so that **liquid** can be charged.
- 2) When using a cylinder equipped with a siphon, liquid can be charged without turning it upside down.

It is necessary for charging refrigerant under condition of liquid because R410A is mixed type of refrigerant. Accordingly, when charging refrigerant from the refrigerant cylinder to the equipment, charge it turning the cylinder upside down if cylinder is not equipped with siphon.



R410A refrigerant is HFC mixed refrigerant. Therefore, if it is charged with gas, the composition of the charged refrigerant changes and the characteristics of the equipment varies.

Fig. 6-4-2

6-5. Brazing of Pipes

6-5-1. Materials for Brazing

1. Silver brazing filler

Silver brazing filler is an alloy mainly composed of silver and copper.

It is used to join iron, copper or copper alloy, and is relatively expensive though it excels in solderability.

2. Phosphor bronze brazing filler

Phosphor bronze brazing filler is generally used to join copper or copper alloy.

3. Low temperature brazing filler

Low temperature brazing filler is generally called solder, and is an alloy of tin and lead.

Since it is weak in adhesive strength, do not use it for refrigerant pipes.

- 1) Phosphor bronze brazing filler tends to react with sulfur and produce a fragile compound water solution, which may cause a gas leakage. Therefore, use any other type of brazing filler at a hot spring resort, etc., and coat the surface with a paint.
- 2) When performing brazing again at time of servicing, use the same type of brazing filler.

6-5-2. Flux

1. Reason why flux is necessary

- By removing the oxide film and any foreign matter on the metal surface, it assists the flow of brazing filler.
- In the brazing process, it prevents the metal surface from being oxidized.
- By reducing the brazing filler's surface tension, the brazing filler adheres better to the treated metal.

2. Characteristics required for flux

- Activated temperature of flux coincides with the brazing temperature.
- Due to a wide effective temperature range, flux is hard to carbonize.
- It is easy to remove slag after brazing.
- The corrosive action to the treated metal and brazing filler is minimum.
- It excels in coating performance and is harmless to the human body.

As the flux works in a complicated manner as described above, it is necessary to select an adequate type of flux according to the type and shape of treated metal, type of brazing filler and brazing method, etc.

3. Types of flux

• Noncorrosive flux

Generally, it is a compound of borax and boric acid.

It is effective in case where the brazing temperature is higher than 800°C.

• Activated flux

Most of fluxes generally used for silver brazing are this type.

It features an increased oxide film removing capability due to the addition of compounds such as potassium fluoride, potassium chloride and sodium fluoride to the borax-boric acid compound.

4. Piping materials for brazing and used brazing filler/flux

Piping material	Used brazing filler	Used flux
Copper - Copper	Phosphor copper	Do not use
Copper - Iron	Silver	Paste flux
Iron - Iron	Silver	Vapor flux

- 1) Do not enter flux into the refrigeration cycle.
- 2) When chlorine contained in the flux remains within the pipe, the lubricating oil deteriorates. Therefore, use a flux which does not contain chlorine.
- 3) When adding water to the flux, use water which does not contain chlorine (e.g. distilled water or ion-exchange water).
- 4) Remove the flux after brazing.

6-5-3. Brazing

As brazing work requires sophisticated techniques, experiences based upon a theoretical knowledge, it must be performed by a person qualified.

In order to prevent the oxide film from occurring in the pipe interior during brazing, it is effective to proceed with brazing while letting dry Nitrogen gas flow.

Never use gas other than Nitrogen gas.

1. Brazing method to prevent oxidation

- 1) Attach a reducing valve and a flow-meter to the Nitrogen gas cylinder.
- 2) Use a copper pipe to direct the piping material, and attach a flow-meter to the cylinder.
- 3) Apply a seal onto the clearance between the piping material and inserted copper pipe for Nitrogen in order to prevent backflow of the Nitrogen gas.
- 4) When the Nitrogen gas is flowing, be sure to keep the piping end open.
- 5) Adjust the flow rate of Nitrogen gas so that it is lower than 0.05 m³/Hr or 0.02 MPa (0.2kgf/cm²) by means of the reducing valve.
- 6) After performing the steps above, keep the Nitrogen gas flowing until the pipe cools down to a certain extent (temperature at which pipes are touchable with hands).
- 7) Remove the flux completely after brazing.

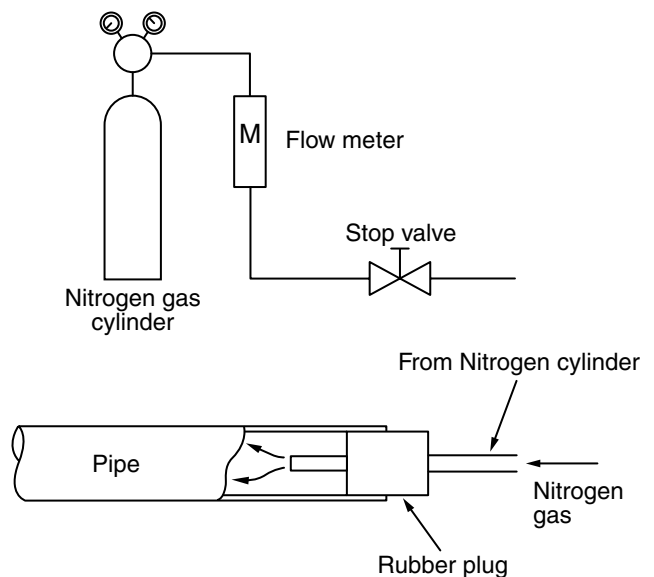

Fig. 6-5-1 Prevention of oxidation during brazing

6-6. Instructions for Re-use Piping of R22 or R407C

Instruction of Works:

The existing R22 and R407C piping can be reused for our digital inverter R410A products installations.

NOTE)

Confirmation of existence of scratch or dent of the former pipes to be applied and also confirmation of reliability of the pipe strength are conventionally referred to the local site.

If the definite conditions can be cleared, it is possible to update the existing R22 and R407C pipes to those for R410A models.

6-6-1. Basic Conditions Needed to Reuse the Existing Pipe

Check and observe three conditions of the refrigerant piping works.

1. Dry (There is no moisture inside of the pipes.)
2. Clean (There is no dust inside of the pipes.)
3. Tight (There is no refrigerant leak.)

6-6-2. Restricted Items to Use the Existing Pipes

In the following cases, the existing pipes cannot be reused as they are. Clean the existing pipes or exchange them with new pipes.

1. When a scratch or dent is heavy, be sure to use the new pipes for the works.
2. When the thickness of the existing pipe is thinner than the specified "Pipe diameter and thickness" be sure to use the new pipes for the works.
 - The operating pressure of R410A is high (1.6 times of R22 and R407C). If there is a scratch or dent on the pipe or thinner pipe is used, the pressure strength is poor and may cause breakage of the pipe at the worst.

* Pipe diameter and thickness (mm)

Pipe outer diameter		Ø6.4	Ø9.5	Ø12.7	Ø15.9	Ø19.0
Thickness	R410A	0.8	0.8	0.8	1.0	1.0
	R22 (R407C)					

- In case that the pipe diameter is Ø12.7 mm or less and the thickness is less than 0.7 mm, be sure to use the new pipes for works.
3. The pipes are left as coming out or gas leaks. (Poor refrigerant)
 - There is possibility that rain water or air including moisture enters in the pipe.
 4. Refrigerant recovery is impossible. (Refrigerant recovery by the pump-down operation on the existing air conditioner)
 - There is possibility that a large quantity of poor oil or moisture remains inside of the pipe.
 5. A dryer on the market is attached to the existing pipes.
 - There is possibility that copper green rust generated.

6. Check the oil when the existing air conditioner was removed after refrigerant had been recovered. In this case, if the oil is judged as clearly different compared with normal oil
 - The refrigerator oil is copper rust green : There is possibility that moisture is mixed with the oil and rust generates inside of the pipe.
 - There is discolored oil, a large quantity of the remains, or bad smell.
 - A large quantity of sparkle remained wear-out powder is observed in the refrigerator oil.
7. The air conditioner which compressor was exchanged due to a faulty compressor.

When the discolored oil, a large quantity of the remains, mixture of foreign matter, or a large quantity of sparkle remained wear-out powder is observed, the cause of trouble will occur.
8. Installation and removal of the air conditioner are repeated with temporary installation by lease and etc.
9. In case that type of the refrigerator oil of the existing air conditioner is other than the following oil (Mineral oil), Suniso, Freol-S, MS (Synthetic oil), alkyl benzene (HAB, Barrel-freeze), ester series, PVE only of ether series.
 - Winding-insulation of the compressor may become inferior.

NOTE)

The above descriptions are results of confirmation by our company and they are views on our air conditioners, but they do not guarantee the use of the existing pipes of the air conditioner that adopted R410A in other companies.

6-6-3. Branching Pipe for Simultaneous Operation System

- In the concurrent twin system, when TOSHIBA-specified branching pipe is used, it can be reused. Branching pipe model name: RBC-TWP30E-2. On the existing air conditioner for simultaneous operation system (twin system), there is a case of using branch pipe that has insufficient compressive strength. In this case please change it to the branch pipe for R410A.

6-6-4. Curing of Pipes

When removing and opening the indoor unit or outdoor unit for a long time, cure the pipes as follows:

- Otherwise rust may generate when moisture or foreign matter due to dewing enters in the pipes.
- The rust cannot be removed by cleaning, and a new piping work is necessary.

Place position	Term	Curing manner
Outdoors	1 month or more	Pinching
	Less than 1 month	Pinching or taping
Indoors	Every time	

6-6-5. Final Installation Checks

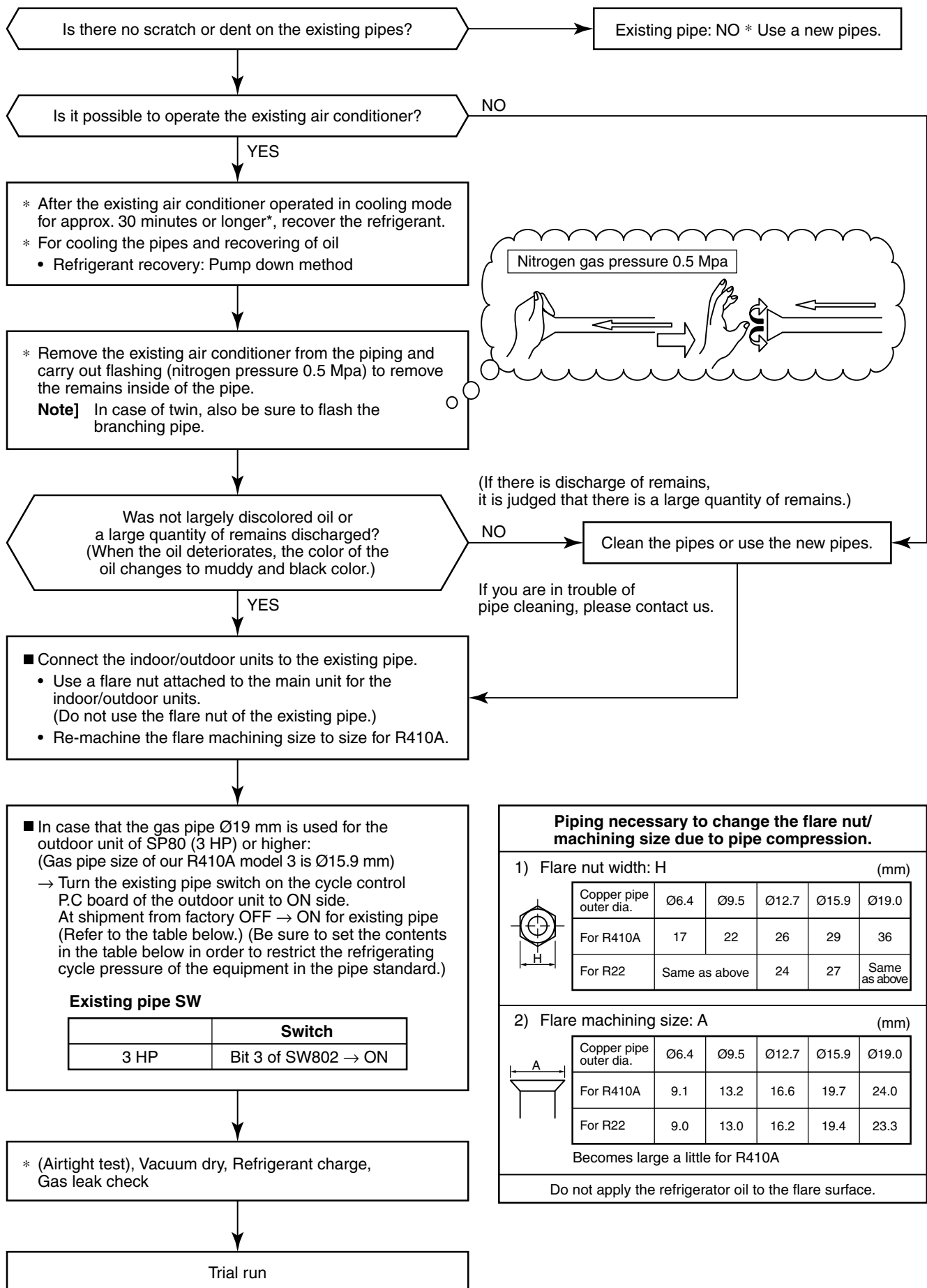

Piping necessary to change the flare nut/ machining size due to pipe compression.

1) Flare nut width: H (mm)

Copper pipe outer dia.	Ø6.4	Ø9.5	Ø12.7	Ø15.9	Ø19.0
For R410A	17	22	26	29	36
For R22	Same as above		24	27	Same as above

2) Flare machining size: A (mm)

Copper pipe outer dia.	Ø6.4	Ø9.5	Ø12.7	Ø15.9	Ø19.0
For R410A	9.1	13.2	16.6	19.7	24.0
For R22	9.0	13.0	16.2	19.4	23.3

Becomes large a little for R410A

Do not apply the refrigerator oil to the flare surface.

6-6-6. Handling of Existing Pipe

When using the existing pipe, carefully check it for the following:

- Wall thickness (within the specified range)
- Scratches and dents
- Water, oil, dirt, or dust in the pipe
- Flare looseness and leakage from welds
- Deterioration of copper pipe and heat insulator

Cautions for using existing pipe

- Do not reuse the flare to prevent gas leak.
Replace it with the supplied flare nut and then process it to a flare.
- Blow nitrogen gas or use an appropriate means to keep the inside of the pipe clean.
If discolored oil or much residue is discharged, wash the pipe.
- Check welds, if any, on the pipe for gas leak.
When the pipe corresponds to any of the following, do not use it. Install a new pipe instead.
- The pipe has been open (disconnected from indoor unit or outdoor unit) for a long period.
- The pipe has been connected to an outdoor unit that does not use refrigerant R22, R410A or R407C.
- The existing pipe must have a wall thickness equal to or larger than the following thickness.

Reference outside diameter (mm)	Wall thickness (mm)
Ø9.5	0.8
Ø15.9	1.0
Ø19.1	1.0

- Never use any pipe with a wall thickness less than these thicknesses due to insufficient pressure capacity.

RAV-SP804ATP*

- To use an existing Ø19.1 mm pipe, set bit 3 of SW802 (switch for existing pipe) on the P.C. board of the outdoor unit to ON.

In this case, the heating performance may be reduced depending on the outside air temperature and room temperature.

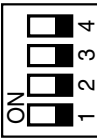
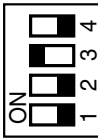
SW802	
When shipped from factory	When using existing pipe
	

6-7. Replenishing refrigerant

In order to assure the reliability of the appliance, the amount of refrigerant to be replenished shall be subject to the following restrictions. Follow the margin of excess replenished refrigerant, which is equivalent to the current R22. Otherwise, abnormally high pressure may be generated in the refrigeration cycle, which may result in failure, explosion of the product, or personal injury.

[Possible gas leakage]

Recharging refrigerant is allowed only if it is confirmed that the amount of leakage (e.g. slow leakage upon installation) is within the additional margin specified below.

The amount of leakage is not certain if the product does not function properly (e.g. insufficient cooling / heating performance). In such case, recover the refrigerant and replenish the refrigerant.

[Restrictions for the amount of additional charging]

- a. The amount of refrigerant additionally charged shall not exceed 10% of that specified. If the situation is not solved with such amount, recover the refrigerant completely and charge the specified amount.
- b. In case of slow leakage upon installation and the pipe connection length of not over 15m, further tighten the flare nut or take other effective measures. Do not recharge the refrigerant.

[Cautions for recharging with refrigerant]

- a. Use a scale with an accuracy of at least 10g to recharge the refrigerant. Do not use a bathroom scale.
- b. If the refrigerant leaks, identify the source and make sure to repair it. The refrigerant gas is not hazardous, but if it touches a heat source (e.g. fan heater, stove), a poisonous gas may be generated.
- c. Use liquid refrigerant for replenishment. Replenish the refrigerant carefully and slowly.

7. OUTDOOR CONTROL CIRCUIT

7-1. Outdoor Controls

1. PMV (Pulse Motor Valve) control

- 1) PMV is controlled between (SP40 to SP56: 20 to 500, SP80: 30 to 500) pulsed during operation.
- 2) In cooling operation, PMV is usually controlled with the temperature difference between TS sensor and TC sensor aiming (SP40 to SP56: 2 to 5K, SP80: 1 to 4K) as the target value.
- 3) In heating operation, PMV is usually controlled with the temperature difference between TS sensor and TE sensor aiming (SP40 to SP56: -2 to 4K, SP80: 2 to 4K) as the target value.
- 4) When the cycle excessively heated in both cooling and heating operation, PMV is controlled by TD sensor.
The target value is 101°C for both cooling and heating operations in SP40 to SP56, and 91°C for cooling operation and 96°C for heating operation respectively in SP80.

REQUIREMENT

A sensor trouble may cause a liquid back-flow or abnormal overheat resulting in excessive shortening of the compressor life.

In a case of trouble on the compressor, be sure to check there is no error in the resistance value or the refrigerating cycle of each sensor after repair and then start the operation.

2. Discharge temperature release control

- 1) When the discharge temperature did not fall or the discharge temperature rapidly went up by PMV control, this control lowers the operation frequency.
It subdivides the frequency control up to 0.6Hz to stabilize the cycle.
- 2) When the discharge temperature detected an abnormal stop zone, the compressor stops and then restarts after 2 minutes 30 seconds.
The error counting is cleared when the operation continued for A minutes. If the error is detected by B times without clearing, the error is determined and restarting is not performed.
* The cause is considered as excessively little amount of refrigerant, PMV error or clogging of the cycle.
- 3) For displayed contents of error, confirm on the check code list.

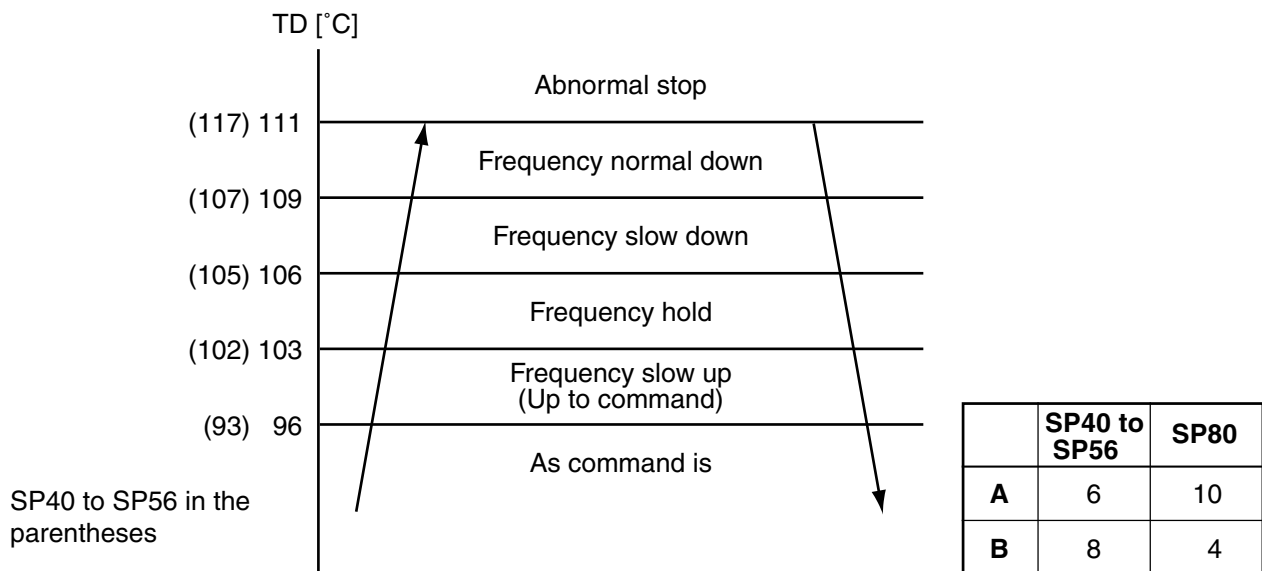

3. Outdoor fan control

Revolution frequency allocation of fan taps [rpm]

	W1	W2	W3	W4	W5	W6	W7	W8	W9	WA	WB	WC	WD	WE	WF
SP40 to SP56	200	250	300	400	480	500	520	560	640	670	700	750	800	880	980
SP80	200	230	260	300	340	380	420	460	520	570	600	630	670	710	740

3-1) Cooling fan control

<SP40 to SP56>

- ① The outdoor fan is controlled by TE sensor, TO sensor and the operation frequency. It is controlled by every 1 tap of DC fan control (15 taps).
- ② Only for 60 seconds after start-up of operation, it is fixed by the maximum fan tap corresponded to the zone in the following table, and then the fan is controlled by temperature of TE sensor.
- ③ When temperature of TD sensor became high sufficiently, it is controlled so that the fan revolution frequency will become higher ignoring TE sensor temperature.

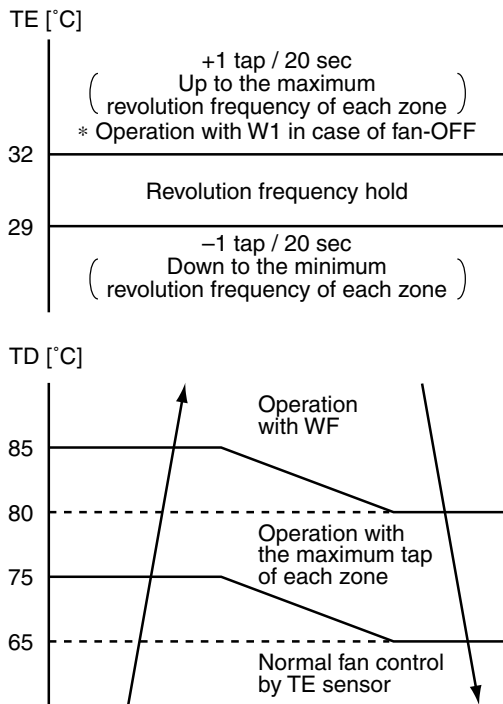

<SP40 to SP56>

Temp. range	20 Hz or lower		20Hz to 45Hz		45Hz or higher	
	Min.	Max.	Min.	Max.	Min.	Max.
38°C ≤ TO	W6	WB	W7	WE	W9	WF
28°C ≤ TO < 38°C	W5	WA	W6	WD	W8	WE
15°C ≤ TO < 28°C	W3	W7	W4	W9	W6	WB
5.5°C ≤ TO < 15°C	W2	W5	W3	W7	W5	W9
0°C ≤ TO < 5.5°C	W1	W3	W2	W5	W3	W7
-5°C ≤ TO < 0°C	W1	W2	W1	W3	W2	W4
TO < -5°C	OFF	OFF	OFF	OFF	W1	W3
TO error	W1	WB	W1	WE	W1	WF

<SP80>

- ① The outdoor fan is controlled by TL sensor, TO sensor and the operation frequency. The outdoor fan is controlled by every 1 tap of DC fan control (15 taps).
- ② Only for 60 seconds after the operation has started, the maximum fan tap corresponding to the zone in the following table is fixed and then the fan is controlled by temperature of TL sensor.

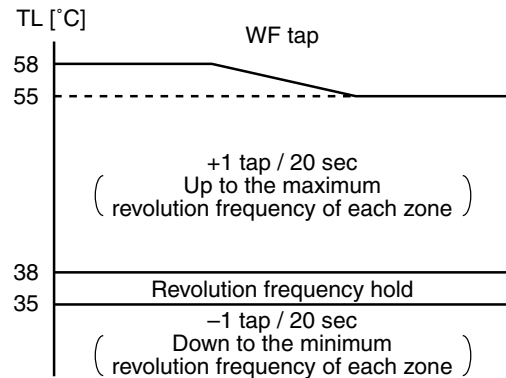

<SP80>

Temp. range	20 Hz or lower		20Hz to 45Hz		45Hz or higher	
	Min.	Max.	Min.	Max.	Min.	Max.
38°C ≤ TO	W6	WC	W8	WE	WA	WE
29°C ≤ TO < 38°C	W5	WB	W7	WD	W9	WD
15°C ≤ TO < 29°C	W4	W8	W6	WA	W8	WC
5°C ≤ TO < 15°C	W3	W6	W5	W8	W7	WA
0°C ≤ TO < 5°C	W2	W4	W4	W6	W5	W8
-4°C ≤ TO < 0°C	W2	W3	W3	W5	W4	W6
TO < -4°C	OFF	OFF	OFF	W2	OFF	W3
TO error	OFF	WC	OFF	WE	OFF	WE

3-2) Heating fan control

- ① The outdoor fan is controlled by TE sensor, TO sensor and the operation frequency.
(Control from minimum W1 to maximum (according to the following table))
- ② For 3 minutes after the operation has started, the maximum fan tap corresponding to the zone in the following table is fixed and then the fan is controlled by temperature of TE sensor.

TE [°C]	Control Action
24	-2 taps / 20 sec. (Down to W1) Stop timer count
21	-2 taps / 20 sec. (Down to W1)
18	-1 tap / 20 sec. (Down to W1)
15	Revolution frequency hold
	+1 tap / 20 sec (Up to the maximum tap of each zone)

- ③ When $TE \geq 24^{\circ}\text{C}$ continues for 5 minutes, the compressor stops.

It is the same status as the normal THERMO OFF without error display.

The compressor restarts after approx. 2 minutes 30 seconds and this intermittent operation is not abnormal.

- ④ In case that the status in item ③ generates frequently, stain on filter of the suction part of the indoor unit is considered.

Clean the filter and then restart the operation.

<SP40 to SP56>

Temp. range	20 Hz or lower	20Hz to 45Hz	45Hz or higher
	Max.	Max.	Max.
$10^{\circ}\text{C} \leq \text{TO}$	W7	W8	W9
$5.5^{\circ}\text{C} \leq \text{TO} < 10^{\circ}\text{C}$	WA	WC	WE
$-5^{\circ}\text{C} \leq \text{TO} < 5.5^{\circ}\text{C}$	WD	WE	WF
$\text{TO} < -5^{\circ}\text{C}$	WE	WF	WF
TO error	WE	WF	WF

<SP80>

Temp. range	20 Hz or lower	20Hz to 45Hz	45Hz or higher
	Max.	Max.	Max.
$10^{\circ}\text{C} \leq \text{TO}$	W7	W8	W9
$5^{\circ}\text{C} \leq \text{TO} < 10^{\circ}\text{C}$	W9	WB	WD
$-3^{\circ}\text{C} \leq \text{TO} < 5^{\circ}\text{C}$	WD	WD	WE
$-10^{\circ}\text{C} \leq \text{TO} < -3^{\circ}\text{C}$	WE	WE	WE
$\text{TO} < -10^{\circ}\text{C}$	WF	WF	WF
TO error	WF	WF	WF

4. Coil heating control

- 1) This control function heats the compressor by turning on the stopped compressor instead of a case heater.
It purposes to prevent stagnation of the refrigerant inside of the compressor.
- 2) As usual, turn on power of the compressor for the specified time before a test run after installation; otherwise a trouble of the compressor may be caused.
As same as a test run, it is recommended to turn on power of the compressor beforehand when starting operation after power of the compressor has been interrupted and left as it is for a long time.
- 3) SP80 judgment for electricity is performed by TD and TO sensors.
If TO sensor is defective, a backup control is automatically performed by TE sensor.
For a case of defective TO sensor, judge it with outdoor LED display.
Using TD sensor and TE sensor, SP40 to SP56 judges the power-on.
- 4) For every model, the power is turned off when TD is 30°C or more.

<SP40 to SP56>

• Power-ON condition TD < 30°C

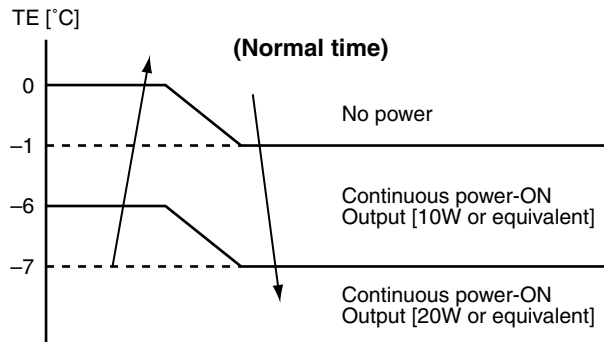

<SP80>

• Power-ON condition TD < 30°C

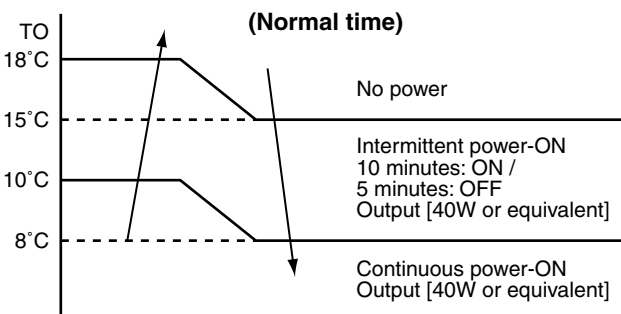

• Power-ON condition TD < 30°C

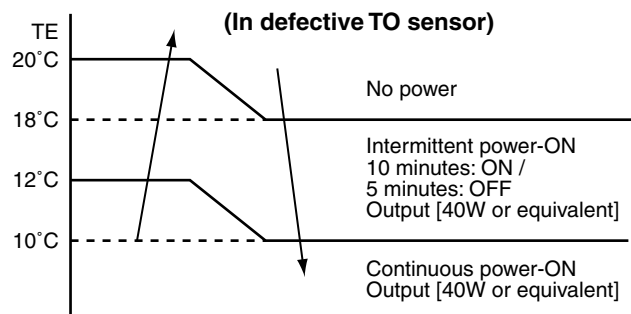

REQUIREMENT

While heating the coil, the power sound may be heard. However it is not a trouble.

5. Short intermittent operation preventive control

- 1) For 3 to 10 minutes after operation start, in some cases, the compressor does not stop to protect the compressor even if receiving the THERMO OFF signal from indoor.
However it is not abnormal status. (The operation continuance differs according to the operation status.)
- 2) When the operation stops by the remote controller, the operation does not continue.

6. Current release control

No. of revolutions of the compressor is controlled by AC current value detected by the outdoor P.C. board so that the input current of the inverter does not exceed the specified value.

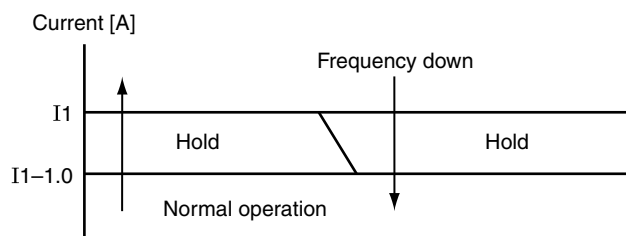

Model	SP40		SP45	
	COOL	HEAT	COOL	HEAT
I1 value [A]	10.80	12.75	10.80	12.75
Model	SP56		SP80	
	COOL	HEAT	COOL	HEAT
I1 value [A]	10.80	13.05	16.0	20.0

7. Current release value shift control

- 1) This control purposes to prevent troubles of the electronic parts such as the compressor driving elements and the compressor during cooling operation.
- 2) The current release control value (I1) is selected from the following table according to TO sensor value.

Current release control value (I1)

[A]

Temperature range	SP40 to SP56	SP80
50°C ≤ TO	7.80	9.5
45°C ≤ TO < 50°C	7.80	9.5
39°C ≤ TO < 45°C	9.30	13.0
TO < 39°C	10.80	16.0
TO error	7.80	9.5

8. Over-current protective control

- 1) When the over-current protective circuit detected an abnormal current, stop the compressor.
- 2) The compressor restarts after 2 minutes 30 seconds as setting [1] as an error count.
- 3) When the error count [8] was found, determine an error and restart operation is not performed.
- 4) For the error display contents, confirm on the check code list.

9. High-pressure release control <SP80 only>

- 1) The operation frequency is controlled to restrain abnormal rising of high pressure by TL sensor in cooling operation and TC sensor in heating operation.
- 2) When TL sensor in cooling operation or TC sensor in heating operation detects abnormal temperature of the stop zone, stop the compressor and the error count becomes +1.
- 3) When the compressor stopped with 2), the operation restarts from the point of the normal operation zone (e point or lower) where it returned after 2 minutes 30 seconds.
- 4) The error count when the compressor stopped with 2) is cleared after the operation continued for 10 minutes.

If the error count becomes [10] without clearing, the error is determined and reactivation is not performed.

- 5) For the error display contents, confirm on the check code list.

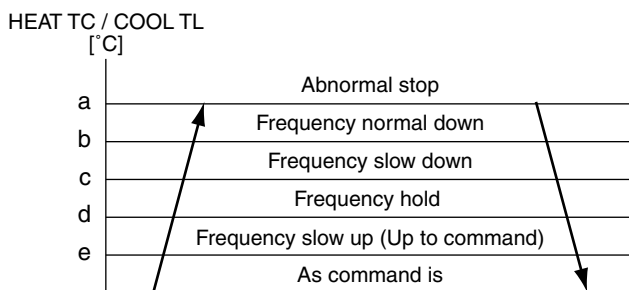

	HEAT	COOL
	TC	TL
a	61°C	63°C
b	56°C	62°C
c	54°C	60°C
d	52°C	58°C
e	48°C	54°C

10. Defrost control

<SP40 to SP56 only>

- 1) In heating operation, defrost operation is performed when TE sensor satisfies any condition in A zone to D zone.
- 2) During defrosting operation, it finishes if TE sensor continued 12°C or continued 5°C ≤ TE < 12°C for 80 seconds. The defrost operation also finishes when it continued for 15 minutes even if TE sensor temperature was 5°C or lower.
- 3) After defrost operation was reset, the compressor stopped for approx. 40 seconds and then the heating operation starts.

Start of heating operation

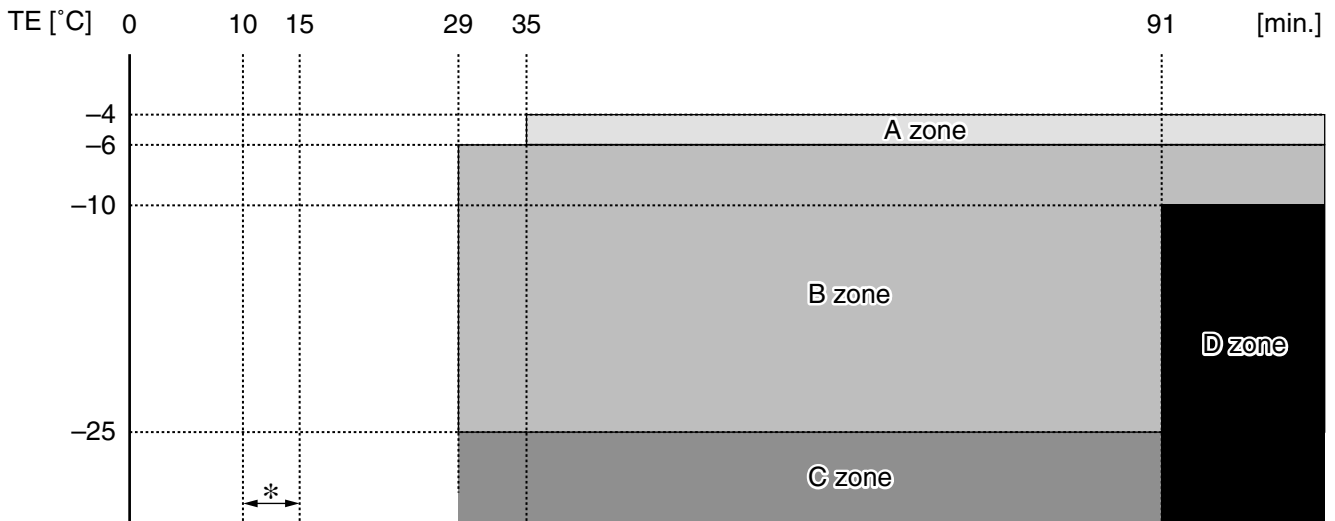

* The minimum TE value and To value between 10 and 15 minutes after heating operation has started are stored in memory as TE0 and To0, respectively.

	In normal To	In abnormal To
A zone	When status $(TE0 - TE) - (To0 - To) \geq 3^{\circ}\text{C}$ continued for 20 seconds	When status $(TE0 - TE) \geq 3^{\circ}\text{C}$ continued for 20 seconds
B zone	When status $(TE0 - TE) - (To0 - To) \geq 2.5^{\circ}\text{C}$ continued for 20 seconds	When status $(TE0 - TE) \geq 2.5^{\circ}\text{C}$ continued for 20 seconds
C zone	When the status $(TE \leq -26^{\circ}\text{C})$ continued for 20 seconds	
D zone	When the status $(TE \leq -10^{\circ}\text{C})$ continued for 20 seconds	

<SP80 only>

- 1) In heating operation, defrost operation is performed when TE sensor satisfies any condition in A zone to D zone.
- 2) During defrosting operation, it finishes if TE sensor continued 12°C or higher for 3 seconds or continued 7°C ≤ TE < 12°C for 1 minute. The defrost operation also finishes when it continued for 10 minutes even if TE sensor temperature was 7°C or lower.
- 3) After defrost operation was reset, the compressor stopped for approx. 40 seconds and then the heating operation starts.

Start of heating operation

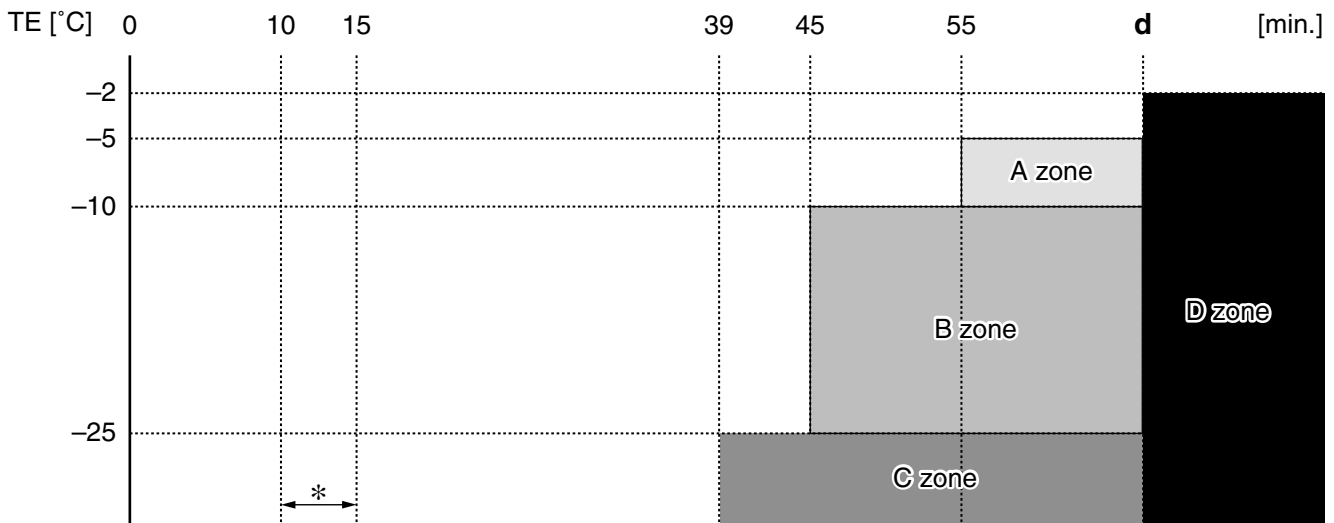

* The minimum TE value and To value between 10 and 15 minutes after heating operation has started are stored in memory as TE0 and To0, respectively.

	In normal To	In abnormal To
A zone	When status $(TE0 - TE) - (To0 - To) \geq 3^{\circ}C$ continued for 20 seconds	When status $(TE0 - TE) \geq 3^{\circ}C$ continued for 20 seconds
B zone	When status $(TE0 - TE) - (To0 - To) \geq 2^{\circ}C$ continued for 20 seconds	When status $(TE0 - TE) \geq 2^{\circ}C$ continued for 20 seconds
C zone	When the status $(TE \leq -25^{\circ}C)$ continued for 20 seconds	
D zone	When compressor operation status of $TE < -2^{\circ}C$ is calculated as d minutes	

- 4) The time of above **d** can be changed by exchanging jumper [J805] and [J806] of the outdoor control P.C. board.
(Setting at shipment: 150 minutes)

J805	J806	d
○	○	150 minutes Setting at shipment
○	×	90 minutes
×	○	60 minutes
×	×	30 minutes

○ : Short circuit, × : Open

11. Compressor protective control <SP80 only>

- 1) This control purposes to raise the operation frequency until 45Hz for 2 minutes in order to protect the compressor (Prevention of oil accumulation in the refrigerating cycle) when the status that the operation frequency is 45Hz or less has continued for 10 hours was calculated. The operation frequency follows the normal indoor command after controlling.
- 2) Although the compressor may stop by THERMO-OFF control when the room temperature varies and then attains the set temperature by this control, it is not abnormal.
- 3) During this control works, if stopping the operation by the remote controller, the operation does not continue.

7-2. Outdoor Print Circuit Board

RAV-SP40*ATP*, SP45*ATP*, SP56*ATP*

<MCC-5009>

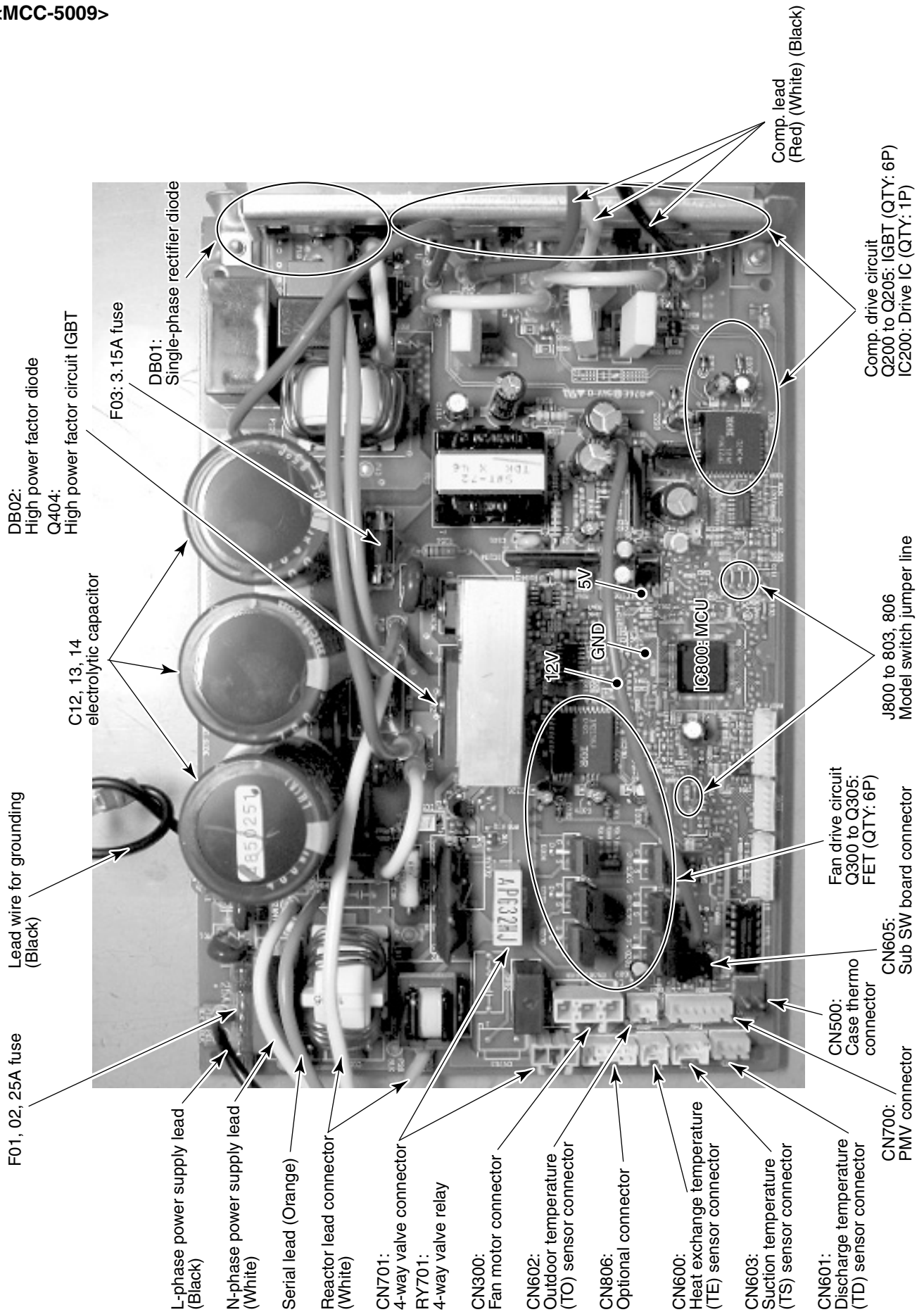

RAV-SP80*ATP*

<MCC-1571>

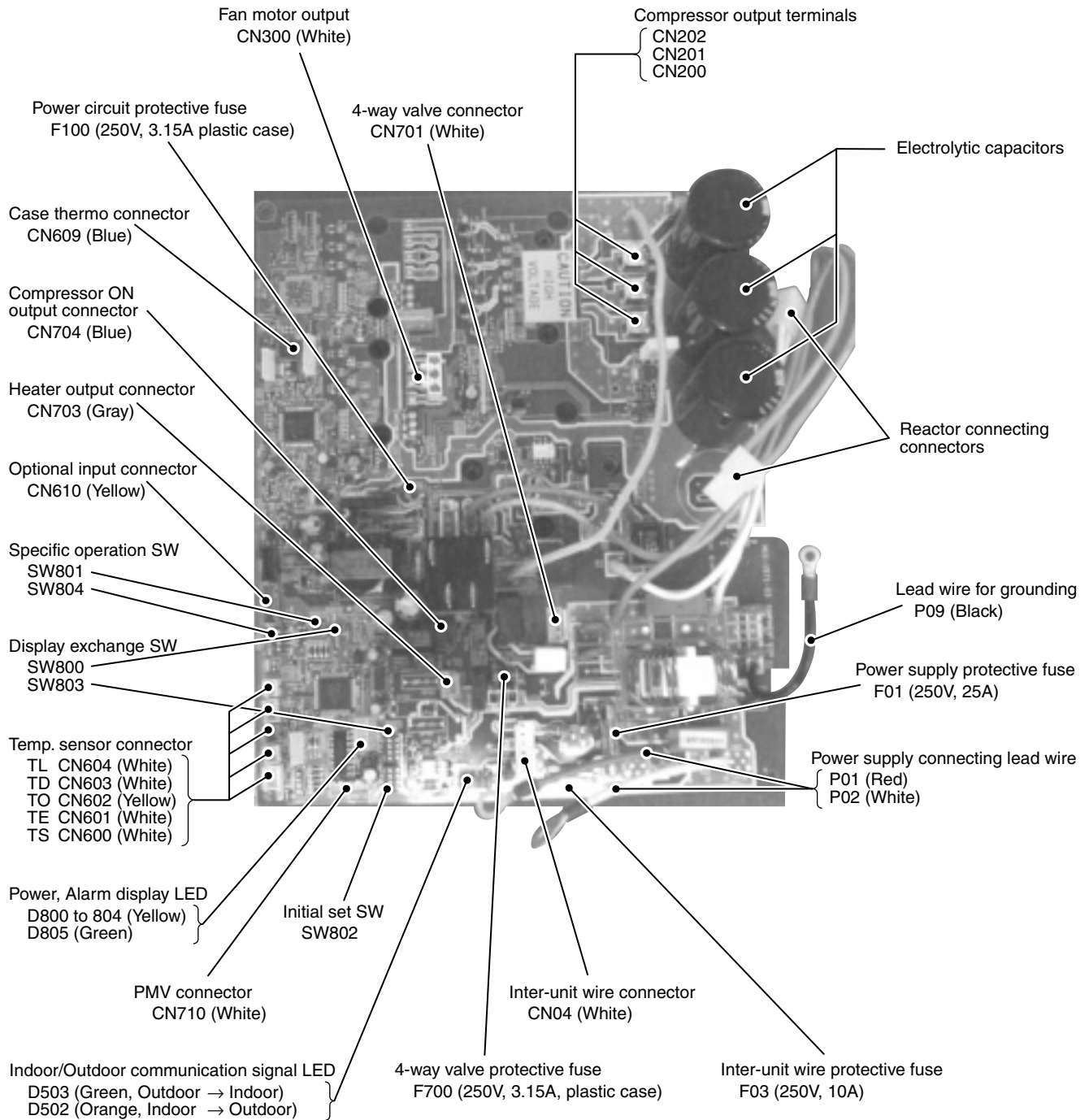

8. TROUBLESHOOTING

8-1. Summary of Troubleshooting

<Wired remote controller type>

1. Before troubleshooting

1) Required tools/instruments

- ⊕ and ⊖ screwdrivers, spanners, radio cutting pliers, nippers, push pins for reset switch
- Tester, thermometer, pressure gauge, etc.

2) Confirmation points before check

a) The following operations are normal.

1. Compressor does not operate.

- Is not 3-minutes delay (3 minutes after compressor OFF)?
- Is not the outdoor unit in standby status though the remote controller reached the setup temperature?
- Does not timer operate during fan operation?
- Is not an overflow error detected on the indoor unit?
- Is not outside high-temperature operation controlled in heating operation?

2. Indoor fan does not rotate.

- Does not cool air discharge preventive control work in heating operation?

3. Outdoor fan does not rotate or air volume changes.

- Does not high-temperature release operation control work in heating operation?
- Does not outside low-temperature operation control work in cooling operation?
- Is not defrost operation performed?

4. ON/OFF operation cannot be performed from remote controller.

- Is not the control operation performed from outside/remote side?
- Is not automatic address being set up?
(When the power is turned on at the first time or when indoor unit address setting is changed, the operation cannot be performed for maximum approx. 5 minutes after power-ON.)
- Is not being carried out a test run by operation of the outdoor controller?

b) Did you return the cabling to the initial positions?

c) Are connecting cables of indoor unit and remote controller correct?

2. Troubleshooting procedure

When a trouble occurred, check the parts along with the following procedure.



NOTE :

For cause of a trouble, power conditions or malfunction/erroneous diagnosis of microcomputer due to outer noise is considered except the items to be checked. If there is any noise source, change the cables of the remote controller to shield cables.

<Wireless remote controller type>**1. Before troubleshooting**

- 1) Required tools/instruments
 - ⊕ and ⊖ screwdrivers, spanners, radio cutting pliers, nippers, etc.
 - Tester, thermometer, pressure gauge, etc.
- 2) Confirmation points before check
 - a) The following operations are normal.
 1. Compressor does not operate.
 - Is not 3-minutes delay (3 minutes after compressor OFF)?
 - Is not the outdoor unit in standby status though the remote controller reached the setup temperature?
 - Does not timer operate during fan operation?
 - Is not an overflow error detected on the indoor unit?
 - Is not outside high-temperature operation controlled in heating operation?
 2. Indoor fan does not rotate.
 - Does not cool air discharge preventive control work in heating operation?
- 3) Outdoor fan does not rotate or air volume changes.
 - Does not high-temperature release operation control work in heating operation?
 - Does not outside low-temperature operation control work in cooling operation?
 - Is not defrost operation performed?
- 4) ON/OFF operation cannot be performed from remote controller.
 - Is not forced operation performed?
 - Is not the control operation performed from outside/remote side?
 - Is not automatic address being set up?
 - Is not being carried out a test run by operation of the outdoor controller?
 - a) Did you return the cabling to the initial positions?
 - b) Are connecting cables between indoor unit and receiving unit correct?

2. Troubleshooting procedure

(When the power is turned on at the first time or when indoor unit address setting is changed, the operation cannot be performed for maximum approx. 5 minutes after power-ON.)

When a trouble occurred, check the parts along with the following procedure.

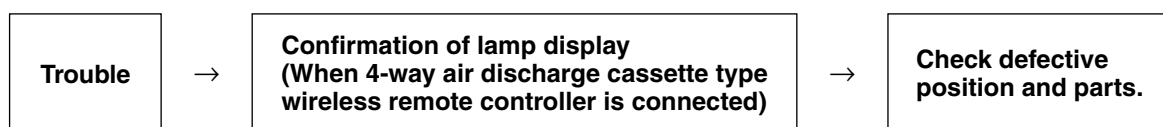

1) Outline of judgment

The primary judgment to check where a trouble occurred in indoor unit or outdoor unit is performed with the following method.

Method to judge the erroneous position by flashing indication on the display part of indoor unit (sensors of the receiving unit)

The indoor unit monitors operating status of the air conditioner, and the blocked contents of self-diagnosis are displayed restricted to the following cases if a protective circuit works.

8-2. Troubleshooting

8-2-1. Outline of judgment

The primary judgment to check whether a trouble occurred in the indoor unit or outdoor unit is carried out with the following method.

Method to judge the erroneous position by flashing indication on the display part of the indoor unit (sensors of the receiving part)

The indoor unit monitors the operating status of the air conditioner, and the blocked contents of self-diagnosis are displayed restricted to the following cases if a protective circuit works.

● : Go off, ○ : Go on,  : Flash (0.5 sec.)

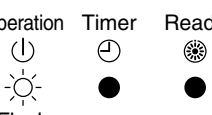
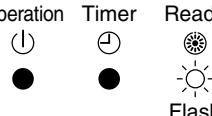
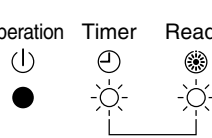
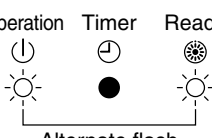



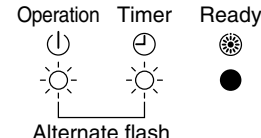
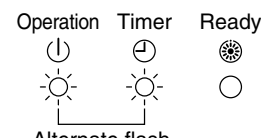
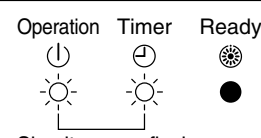
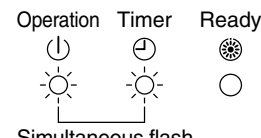
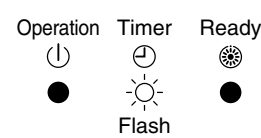
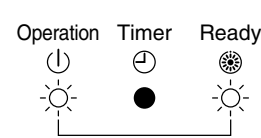
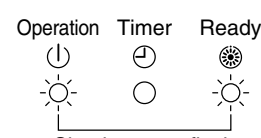







Lamp indication	Check code	Cause of trouble occurrence
Operation Timer Ready  ● ● ● No indication at all	—	Power supply OFF or miswiring between receiving unit and indoor unit
Operation Timer Ready  Flash	E01	Receiving error } Receiving unit } Sending error } Communication stop } Miswiring or wire connection error between receiving unit and indoor unit
	E02	
	E03	
	E08	Duplicated indoor unit No. } Duplicated master units of remote controller } Setup error
	E09	
	E10	Communication error between CPUs on indoor unit P.C. board
E18	Wire connection error between indoor units, Indoor power OFF (Communication stop between indoor master and follower or between main and sub indoor twin)	
Operation Timer Ready  Flash	E04	Miswiring between indoor unit and outdoor unit or connection error (Communication stop between indoor and outdoor units)
Operation Timer Ready  Alternate flash	P10	Overflow was detected. } Indoor DC fan error } Protective device of indoor unit worked.
	P12	
Operation Timer Ready  Alternate flash	P03	Outdoor unit discharge temp. error } Outdoor high pressure system error } Protective device of outdoor unit worked. *1
	P04	
	P05	Power supply voltage error } Heat sink overheat error } Gas leak detection error } Outdoor unit error
	P07	
	P15	
	P19	4-way valve system error (Indoor or outdoor unit judged.)
	P20	Outdoor unit high pressure protection
	P22	Outdoor fan system error } Short-circuit error of compressor driving device } Position detection circuit error } Protective device of outdoor unit worked. *1
	P26	
	P29	
P31	Stopped because of error of other indoor unit in a group (Check codes of E03/L03/L07/L08)	

*1: These are representative examples and the check code differs according to the outdoor unit to be combined.

Lamp indication	Check code	Cause of trouble occurrence
Operation Timer Ready 	F01	Heat exchanger sensor (TCJ) error Heat exchanger sensor (TC) error Heat exchanger sensor (TA) error } Indoor unit sensor error
	F02	
	P10	
Operation Timer Ready 	F04	Discharge temp. sensor (TD) error Temp. sensor (TE) error Temp. sensor (TL) error Temp. sensor (TO) error Temp. sensor (TS) error Temp. sensor (TH) error Temp. sensor miswiring (TE, TS) } Sensor error of outdoor unit *1
	F06	
	F07	
	F08	
	F12	
	F13	
	F15	
Operation Timer Ready 	F29	Indoor EEPROM error
Operation Timer Ready 	F31	Outdoor EEPROM error
Operation Timer Ready 	H01	Compressor break down Compressor lock Current detection circuit error Case thermostat worked. } Outdoor compressor system error *1
	H02	
	H03	
	H04	
Operation Timer Ready 	L03	Duplicated master indoor units There is indoor unit of group connection in individual indoor unit. Unsetting of group address Missed setting (Unset indoor capacity) } → AUTO address * If group construction and address are not normal when power supply turned on, automatically goes to address setup mode.
	L07	
	L08	
	L09	
Operation Timer Ready 	L10	Unset model type (Service board) Duplicated indoor central addresses Other error of outdoor unit Outside interlock error } Others
	L20	
	L29	
	L30	

*1: These are representative examples and the check code differs according to the outdoor unit to be combined.

8-2-2. Others (Other than Check Code)

Lamp indication	Check code	Cause of trouble occurrence
<p>Operation Timer Ready</p> <p>  </p> <p>  </p> <p>Simultaneous flash</p>	<p>—</p>	<p>During test run</p>
<p>Operation Timer Ready</p> <p>  </p> <p>  </p> <p>Alternate flash</p>	<p>—</p>	<p>Disagreement of cool/heat (Automatic cool/heat setting to automatic cool/heat prohibited model, or setting of heating to cooling-only model)</p>

Check Code List (Outdoor)

ALT (Alternate): Alternate flashing when there are two flashing LED SIM (Simultaneous): Simultaneous flashing when there are two flashing LED
 ○ : Go on, ⊙ : Flash, ● : Go off

Remote controller indication	Sensor lamp part		Representative defective position	Detection	Explanation of error contents	Automatic reset	Operation continuation
	Block indication	Ready					
F04	⊙	⊙	Outdoor unit Discharge temp. sensor (TD) error	Outdoor	Open/Short of discharge temp. sensor was detected.	X	X
F06	⊙	○	Outdoor unit Temp. sensor (TE, TS, TL) error	Outdoor	Open/Short of heat exchanger temp. sensor was detected. Miswiring between TE sensor and TS sensor	X	X
F08	⊙	○	Outdoor unit Outside temp. sensor (TO) error	Outdoor	Open/Short of outside temp. sensor was detected.	○	○
F07	⊙	○	Outdoor unit Temp. sensor (TL) error	Outdoor	Open/Short of heat exchanger temp. sensor was detected.	X	X
F12	⊙	○	Outdoor unit Temp. sensor (TS) error	Outdoor	Open/Short of heat exchanger temp. sensor was detected.	X	X
F13	⊙	○	Outdoor unit Temp. sensor (TH) error	Outdoor	Open/Short of heat sink temp. sensor (Board installed) was detected.	X	X
F15	⊙	○	Outdoor unit Misconnection of temp. sensor (TE, TS)	Outdoor	Misconnection of outdoor heat exchanger temp. sensor and suction temp. sensor was detected.	X	X
F31	⊙	○	Outdoor unit EEPROM error	Outdoor	Outdoor P.C. board part (EEPROM) error was detected.	X	X
H01	●	●	Outdoor unit Compressor break down	Outdoor	When reached min-Hz by current release control, short-circuited current (Idc) after DC excitation was detected.	X	X
H02	●	●	Outdoor unit Compressor lock	Outdoor	Compressor lock was detected.	X	X
H03	●	●	Outdoor unit Current detection circuit error	Outdoor	Current detection circuit error	X	X
H04	●	●	Outdoor unit Case thermostat operation	Outdoor	Case thermostat operation was detected.	X	X
L10	⊙	⊙	Outdoor unit Setting error of service P.C. board type	Outdoor	When outdoor service P.C. board was used, model type select jumper setting was inappropriate.	X	X
L29	⊙	○	Outdoor unit Other outdoor unit error	Outdoor	1) Defective parts on outdoor P.C. board (MCU communication, EEPROM, TH sensor error) 2) When outdoor service P.C. board was used, model type selection was inappropriate. 3) Other error (Heat sink abnormal overheating, gas leak, 4-way valve inverse error) was detected.	X	X
P03	⊙	⊙	Outdoor unit Discharge temp. error	Outdoor	Error was detected by discharge temp. release control.	X	X
P04	⊙	⊙	Outdoor unit High pressure system error, Power supply voltage error	Outdoor	When case thermostat worked, error was detected by high release control from indoor/outdoor heat exchanger temp. sensor. Power supply voltage error	X	X
P05	⊙	⊙	Power supply error	Outdoor	Power supply voltage error	X	X
P07	⊙	⊙	Outdoor unit Heat sink overheating	Outdoor	Abnormal overheating was detected by outdoor heat sink temp. sensor.	X	X
P15	⊙	⊙	Gas leak detection	Outdoor	Abnormal overheating of discharge temp. or suction temp. was detected.	X	X
P20	⊙	⊙	Outdoor unit High pressure system error	Outdoor	Error was detected by high release control from indoor/outdoor heat exchanger temp. sensor.	X	X
P22	⊙	⊙	Outdoor unit Outdoor fan error	Outdoor	Error (Over-current, lock, etc.) was detected on outdoor fan drive circuit.	X	X
P26	⊙	⊙	Outdoor unit Inverter Idc operation	Outdoor	Short-circuited protective operation of compressor drive circuit element (G-Tr /IGBT) worked.	X	X
P29	⊙	⊙	Outdoor unit Position detection error	Outdoor	Position detection error of compressor motor was detected.	X	X
E01	⊙	●	No remote controller master unit Remote controller communication error	Remote controller	Signal was not received from indoor unit. Main remote controller was not set. (including 2 remote controllers)	—	—
E02	⊙	●	Remote controller send error	Remote controller	Signal cannot be sent to indoor unit.	—	—
E03	⊙	●	Regular communication error between indoor and remote controller	Indoor	No communication from remote controller and network adapter	○	X
E04	●	⊙	Indoor/Outdoor serial error	Indoor	Serial communication error between indoor and outdoor	○	X
E08	⊙	●	Duplicated indoor addresses	Indoor	Same address as yours was detected.	○	○
E09	⊙	●	Duplicated main remote controllers	Remote controller	In 2-remote controller control, both were set as master. (Indoor master unit stops warning and follower unit continues operation.)	X	X
E10	⊙	●	Communication error between CPU	Indoor	MCU communication error between main motor and micro computer	○	△
E18	⊙	●	Regular communication error between master and follower indoor units	Indoor	Regular communication was impossible between master and follower indoor units. Communication between twin master (Main unit) and follower (sub unit) was impossible.	○	X
L03	⊙	●	Duplicated indoor master units	Indoor	There are multiple master units in a group.	X	X
L07	⊙	●	There is group cable in individual indoor unit.	Indoor	When even one group connection indoor unit exists in individual indoor unit	X	X
L08	⊙	●	Unset indoor group address	Indoor	Indoor address group was unset.	X	X
L09	⊙	●	Unset indoor capacity	Indoor	Capacity of indoor unit was unset.	X	X
L30	⊙	○	Outside error input to indoor unit (Interlock)	Indoor	Abnormal stop by CN80 outside error input	X	X
P19	⊙	●	4-way valve inverse error	Indoor Outdoor	In heating operation, error was detected by temp. down of indoor heat exchanger or temp. up of TE, TS.	○	X

◇ When this warning was detected before group construction/address check finish at power supply was turned on, the mode shifts automatically to AUTO address setup mode.

○ : Go on, ◎ : Flash, ● : Go off
 ALT (Alternate): Alternate flashing when there are two flashing LED SIM (Simultaneous): Simultaneous flashing when there are two flashing LED

Remote controller indication	Sensor lamp part			Representative defective position	Detection	Explanation of error contents	Automatic reset	Operation continuation
	Block indication	Timer	Ready					
F01	◎	◎	◎	Indoor unit Heat exchanger sensor (TCJ) error	Indoor	Open/Short of heat exchanger (TCJ) was detected.	○	X
F02	◎	◎	◎	Indoor unit Heat exchanger sensor (TC) error	Indoor	Open/Short of heat exchanger (TC) was detected.	○	X
F10	◎	◎	◎	Indoor unit Room temp. sensor (TA) error	Indoor	Open/Short of room temp. (TA) was detected.	○	X
F29	◎	◎	◎	Indoor unit Other indoor PC. board error	Indoor	EEPROM error (Other error may be detected. If no error, automatic address is repeated.)	X	X
P01	●	◎	◎	Indoor unit Indoor fan error	Indoor	Indoor AC fan error was detected. (Fan thermal relay worked.)	X	X
P10	●	◎	◎	Indoor unit Overflow detection	Indoor	Float switch worked.	X	X
P12	●	◎	◎	Indoor unit Indoor fan error	Indoor	Indoor fan error (Over-current / Lock, etc.) was detected.	X	X
P31	◎	●	◎	Other indoor unit error	Indoor	Other indoor under condition of warning in group. E03/L07/L09/L08 warning	○	X
—	By unit with warning No.	—	—	Error in indoor group	Network adapter/Center	Sub remote controller error in a group (Details of remote controller are displayed with unit No. Only central control side is displayed.)	—	—
—	—	—	—	LAN system communication error	Network adapter/Center	Communication error of central control system signal * is not displayed on the remote controller	○	○
L20	◎	○	◎	LAN system communication error	Network adapter/Center	Duplicated indoor address of central control system communication	○	X
—	—	—	—	There are multiple communication adapters.	Network adapter	There are multiple communication adapters on remote controller communication line.	○	○

Error mode detected by indoor unit

Operation of diagnostic function				Judgment and measures
Check code	Cause of operation	Status of air conditioner	Condition	
E03	No communication from remote controller (including wireless) and communication adapter	Stop (Automatic reset)	Displayed when error is detected	1. Check cables of remote controller and communication adapters. • Remote controller LCD display OFF (Disconnection) • Central remote controller [97] check code
E04	The serial signal is not output from outdoor unit to indoor unit. • Miswiring of inter-unit wire • Defective serial sending circuit on outdoor P.C. board • Defective serial receiving circuit on indoor P.C. board	Stop (Automatic reset)	Displayed when error is detected	1. Outdoor unit does not completely operate. • Inter-unit wire check, correction of miswiring • Check outdoor P.C. board. Correct wiring of P.C. board. 2. When outdoor unit normally operates Check P.C. board (Indoor receiving / Outdoor sending).
E08	Duplicated indoor unit address	Stop	Displayed when error is detected	1. Check whether remote controller connection (Group/Individual) was changed or not after power supply turned on (Finish of group construction/Address check). * If group construction and address are not normal when the power has been turned on, the mode automatically shifts to address setup mode. (Resetting of address)
L03	Duplicated indoor master unit			
L07	There is group wire in individual indoor unit.			
L08	Unset indoor group address			
L09	Unset indoor capacity	Stop	Displayed when error is detected	1. Set indoor capacity (DN=11)
L30	Abnormal input of outside interlock	Stop	Displayed when error is detected	1. Check outside devices. 2. Check indoor P.C. board.
P10	Float switch operation • Float circuit, Disconnection, Coming-off, Float switch contact error	Stop	Displayed when error is detected	1. Trouble of drain pump 2. Clogging of drain pump 3. Check float switch. 4. Check indoor P.C. board.
P12	Indoor DC fan error	Stop	Displayed when error is detected	1. Position detection error 2. Over-current protective circuit of indoor fan driving unit operated. 3. Indoor fan locked. 4. Check indoor P.C. board.
P19	4-way valve system error • After heating operation has started, indoor heat exchangers temp. is down.	Stop (Automatic reset)	Displayed when error is detected	1. Check 4-way valve. 2. Check 2-way valve and check valve. 3. Check indoor heat exchanger (TC/TCJ). 4. Check indoor P.C. board.
P31	Own unit stops while warning is output to other indoor units.	Stop (Follower unit) (Automatic reset)	Displayed when error is detected	1. Judge follower unit while master unit is [E03], [L03], [L07] or [L08]. 2. Check indoor P.C. board.
F01	Coming-off, disconnection or short of indoor heat exchanger temp. sensor (TCJ)	Stop (Automatic reset)	Displayed when error is detected	1. Check indoor heat exchanger temp. sensor (TCJ). 2. Check indoor P.C. board.
F02	Coming-off, disconnection or short of indoor heat exchanger temp. sensor (TC)	Stop (Automatic reset)	Displayed when error is detected	1. Check indoor heat exchanger temp. sensor (TC). 2. Check indoor P.C. board.
F10	Coming-off, disconnection or short of indoor heat exchanger temp. sensor (TA)	Stop (Automatic reset)	Displayed when error is detected	1. Check indoor heat exchanger temp. sensor (TA). 2. Check indoor P.C. board.
F29	Indoor EEPROM error • EEPROM access error	Stop (Automatic reset)	Displayed when error is detected	1. Check indoor EEPROM. (including socket insertion) 2. Check indoor P.C. board.
E10	Communication error between indoor MCU • Communication error between fan driving MCU and main MCU	Stop (Automatic reset)	Displayed when error is detected	1. Check indoor P.C. board.
E18	Regular communication error between indoor master and follower units and between main and sub units	Stop (Automatic reset)	Displayed when error is detected	1. Check remote controller wiring. 2. Check indoor power supply wiring. 3. Check indoor P.C. board.

Error mode detected by remote controller or central controller (TCC-LINK)

Operation of diagnostic function				Judgment and measures
Check code	Cause of operation	Status of air conditioner	Condition	
Not displayed at all (Operation on remote controller is impossible.)	No communication with master indoor unit <ul style="list-style-type: none"> Remote controller wiring is not correct. Power of indoor unit is not turned on. Automatic address cannot be completed. 	Stop	—	Power supply error of remote controller, Indoor EEPROM error <ol style="list-style-type: none"> 1. Check remote controller inter-unit wiring. 2. Check remote controller. 3. Check indoor power wiring. 4. Check indoor P.C. board. 5. Check indoor EEPROM. (including socket insertion) <ul style="list-style-type: none"> → Automatic address repeating phenomenon generates.
E01 *2	No communication with master indoor unit <ul style="list-style-type: none"> Disconnection of inter-unit wire between remote controller and master indoor unit (Detected by remote controller side) 	Stop (Automatic reset) * If center exists, operation continues.	Displayed when error is detected	Receiving error from remote controller <ol style="list-style-type: none"> 1. Check remote controller inter-unit wiring. 2. Check remote controller. 3. Check indoor power wiring. 4. Check indoor P.C. board.
E02	Signal send error to indoor unit (Detected by remote controller side)	Stop (Automatic reset) * If center exists, operation continues.	Displayed when error is detected	Sending error of remote controller <ol style="list-style-type: none"> 1. Check sending circuit inside of remote controller. <ul style="list-style-type: none"> → Replace remote controller.
E09	There are multiple main remote controllers. (Detected by remote controller side)	Stop (Sub unit continues operation.)	Displayed when error is detected	1. In 2-remote controllers (including wireless), there are multiple main units. Check that there are 1 main remote controller and other sub remote controllers.
L20 ----- Central controller L20	Duplicated indoor central addresses on communication of central control system (Detected by indoor/central controller side)	Stop (Automatic reset)	Displayed when error is detected	1. Check setting of central control system network address. (Network adapter SW01) 2. Check network adapter P.C. board.
— *3 ----- Central controller (Send) C05 (Receive) C06	Communication circuit error of central control system (Detected by central controller side)	Continues (By remote controller)	Displayed when error is detected	1. Check communication wire / miswiring 2. Check communication (U3, U4 terminals) 3. Check network adapter P.C. board. 4. Check central controller (such as central control remote controller, etc.) 5. Check terminal resistance. (TCC-LINK)
— ----- Central controller P30	Indoor Gr sub unit error (Detected by central controller side)	Continuation/Stop (According to each case)	Displayed when error is detected	Check the check code of the corresponding unit from remote controller.

*2 The check code cannot be displayed by the wired remote controller.
(Usual operation of air conditioner becomes unavailable.)

For the wireless models, an error is notified with indication lamp.

*3 This trouble is related to communication of remote controller (A, B), central system (TCC-LINK U3, U4), and [E01], [E02], [E03], [E09] or [E18] is displayed or no check display on the remote controller according to the contents.

Error mode detected by outdoor unit

Operation of diagnostic function				Judgment and measures
Check code	Cause of operation	Status of air conditioner	Condition	
Indoor unit				
after 4 series				
F04*	Disconnection, short-circuit of discharge temp. sensor (TD)	Stop	Displayed when error is detected	1. Check discharge temp. sensor (TD). 2. Check outdoor P.C. board.
F06*	Disconnection, or short-circuit of outdoor temp. sensor (TE)	Stop	Displayed when error is detected	1. Check temp. sensor (TE). 2. Check outdoor P.C. board.
F07	Disconnection, or short-circuit of outdoor temp. sensor (TL)	Stop	Displayed when error is detected	1. Check temp. sensor (TL). 2. Check outdoor P.C. board.
F12*	Disconnection, or short-circuit of suction temp. sensor (TS)	Stop	Displayed when error is detected	1. Check suction temp. sensor (TS). 2. Check outdoor P.C. board.
F15	Miss-mounting of outdoor temp. sensor (TE, TS)	Stop	Displayed when error is detected	1. Check temp. sensor (TE, TS). 2. Check outdoor P.C. board.
F08*	Disconnection, or short-circuit of outside temp. sensor (TO)	Continue	Displayed when error is detected	1. Check outside temp. sensor (TO). 2. Check outdoor P.C. board.
F13	Disconnection, or short-circuit of heat sink temp. sensor (TH)	Stop	Displayed when error is detected	1. Check outdoor P.C. board.
F31	Outdoor P.C. EEPROM error	Stop	Displayed when error is detected	1. Check outdoor P.C. board.
L10	Incorrect setting of service P.C. board	Stop	Displayed when error is detected	1. Outdoor service P.C. board Check model type setting jumper wire.
L29*	Communication error between MCUs on outdoor P.C. board	Stop	Displayed when error is detected	1. Check outdoor P.C. board.
P07	Heat sink overheat error * Heat sink temp. sensor detected over the specified temperature.	Stop	Displayed when error is detected	1. Check screw tightening between PC. Board and heat sink and check radiator grease. 2. Check heat sink cooling.
P15	Detection of gas leak * Discharge temp. sensor (TD), Suction temp. sensor (TS) detected temperature over the specified temp.	Stop	Displayed when error is detected	1. Check gas leak. 2. Check whether the service valve is fully opened. 3. Check PMV (Pulse Motor Valve). 4. Check broken pipe. 5. Check discharge temp. sensor (TD), suction temp. sensor (TS).
P19	4-way valve inverse error * After heating operation has started, indoor heat exchanger temp. lowers under the specified temp. * After heating operation has started, outdoor heat exchanger / suction temp. rises over the specified temp.	Stop	Displayed when error is detected	1. Check operation of 4-way valve. 2. Check outdoor heat exchanger (TE), suction temp. sensor (TS). 3. Check indoor heat exchanger sensor (TC). 4. Check 4-way valve coil. 5. Check PMV (Pulse Motor Valve).
H01*	Compressor break down * Although operation has started, operation frequency decreases and operation stops.	Stop	Displayed when error is detected	1. Check power supply voltage. (AC198 to 264V) 2. Overload operation of refrigerating cycle
H02*	Compressor lock * Over-current detection after compressor start-up	Stop	Displayed when error is detected	1. Trouble of compressor (Lock, etc.): Replace compressor. 2. Wiring error of compressor (Open circuit)
H03*	Current detection circuit error	Stop	Displayed when error is detected	1. Check outdoor P.C. board. (AC current detection circuit)

* : AP40 to AP56 is only.

Operation of diagnostic function				Judgment and measures
Check code	Cause of operation	Status of air conditioner	Condition	
Indoor unit				
after 4 series				
P03*	Discharge temp. error * Discharge temp. (TD) detected temperature over the specified temp.	Stop	Displayed when error is detected	1. Check refrigerating cycle (Gas leak) 2. Trouble of electronic expansion valve 3. Check discharge temp. sensor (TD).
H04	Case thermostat operation * Abnormal overheat of compressor	Stop	Displayed when error is detected	1. Check case thermostat and connector. 2. Check gas leak, recharge 3. Check whether the service valve is fully opened. 4. Check PMV (Pulse Motor Valve). 5. Check broken pipe.
P05*	Power supply voltage error	Stop	Displayed when error is detected	1. Check power supply voltage. AC198 to 264V
P20	High pressure protective operation • During cooling operation, outdoor temp. sensor (TL) detected temperature over specified temp. • During heating operation, indoor temp. sensor (TC, TCJ) detected temperature over specified temp.	Stop	Displayed when error is detected	1. Check outdoor heat exchanger sensor (TL). 2. Check indoor heat exchanger sensor (TC, TCJ). 3. Check full open of service valve. 4. Check indoor/outdoor fan. 5. Check PMV (Pulse Motor Valve). 6. Check clogging and short circuit of indoor/outdoor heat exchanger. 7. Overcharge of refrigerant. Recharge
P22*	Outdoor fan system error	Stop	Displayed when error is detected	1. Check lock of fan motor. 2. Check power supply voltage. AC198 to 264V 3. Check outdoor P.C. board.
P26*	Short-circuit error of compressor driving device	Stop	Displayed when error is detected	1. When performing operation while taking-off compressor wire, P26 error occurs. Check control P.C. board. 2. When performing operation while taking-off compressor wire, an error does not occur. (Compressor rare short)
P29*	Position detection circuit error	Stop	Displayed when error is detected	1. Check control P.C. board.

* : AP40 to AP56 is only.

<In case of SP40 to SP56>

8-2-3. Diagnostic Procedure for Each Check Code (Outdoor Unit)

- 1) This section describes the diagnostic method for each check code displayed on the wired remote controller.
- 2) When “APPLICATION CONTROL KIT” (TCB-PCOS1E2) sold separately is connected, the error contents can be judged by LED on the APPLICATION CONTROL KIT. In this case, turn off both bit 1 and 2 of DIP switch 01 on the All-purpose control kit.

Check code	APPLICATION CONTROL KIT LED display	Check / Countermeasures (Part without special mention indicates a part of the outdoor unit.)
[E04]	—	<p>[Indoor / Outdoor communication error]</p>
[F04]	D01 (Red) ○ D02 (Yellow) ○ D03 (Yellow) ● D04 (Yellow) ●	<p>[Discharge temp. sensor (TD) error]</p>
[F06]	<p>* There is a possibility that any of the following items is not correct. Checking LED on the APPLICATION CONTROL KIT enables you to judge what is incorrect.</p> <div style="display: flex; justify-content: space-around;"> <div data-bbox="267 1630 625 1917"> D01 (Red) ○ D02 (Yellow) ● D03 (Yellow) ● D04 (Yellow) ● </div> <div data-bbox="625 1630 1469 1917"> <p>[Heat exchanger temp. sensor (TE) error]</p> </div> </div> <div style="display: flex; justify-content: space-around; margin-top: 10px;"> <div data-bbox="267 1917 625 2089"> D01 (Red) ● D02 (Yellow) ● D03 (Yellow) ○ D04 (Yellow) ● </div> <div data-bbox="625 1917 1469 2089"> <p>[Suction temp. sensor (TS) error] → Refer to column of [F12].</p> </div> </div>	

LED display legend: ● Go off, ○ Go on, ◎ Flash (5Hz)

<In case of SP40 to SP56>

Check code	APPLICATION CONTROL KIT LED display	Check / Countermeasures (Part without special mention indicates a part of the outdoor unit.)
[F08]	D01 (Red) ● D02 (Yellow) ○ D03 (Yellow) ● D04 (Yellow) ●	<p>[Outside temp. sensor (TO) error]</p> <pre> graph TD Q1{Is connection of CN602 correct? Is resistance value of TO sensor correct?} -- NO --> A1[Correct connector. Sensor error → Replace] Q1 -- YES --> A2[Check outdoor P.C. board. Defect → Replace] </pre>
[F12]	D01 (Red) ● D02 (Yellow) ● D03 (Yellow) ○ D04 (Yellow) ●	<p>[Suction temp. sensor (TS) error]</p> <pre> graph TD Q1{Is connection of CN603 correct? Is resistance value of TS sensor correct?} -- NO --> A1[Correct connector. Sensor error → Replace] Q1 -- YES --> A2[Check outdoor P.C. board. Defect → Replace] </pre>
[H01]	D01 (Red) ◎ D02 (Yellow) ● D03 (Yellow) ◎ D04 (Yellow) ●	<p>[Compressor breakdown]</p> <pre> graph TD Q1{Is AC mains voltage correct? 198 to 264V} -- NO --> A1[Correct power supply line.] Q1 -- YES --> Q2{Is wiring connection correct? Compressor lead (P.C. board side, Compressor side) Reactor cord, Power supply lead} Q2 -- NO --> A2[Check and correct wiring connection.] Q2 -- YES --> Q3{Does abnormal overload happen?} Q3 -- YES --> A3[Remove and improve the cause of overload.] Q3 -- NO --> A4[Check outdoor P.C. board. Defect → Replace] </pre>
[H02]	D01 (Red) ● D02 (Yellow) ● D03 (Yellow) ◎ D04 (Yellow) ●	<p>[Compressor lock]</p> <pre> graph TD Q1{Is AC mains voltage correct? 198 to 264V} -- NO --> A1[Correct power supply line.] Q1 -- YES --> Q2{Is wiring connection correct? Compressor lead (P.C. board side, Compressor side) Reactor cord, Power supply lead} Q2 -- NO --> A2[Check and correct connection of wires.] Q2 -- YES --> Q3{Is compressor under correct conditions?} Q3 -- NO --> Q4{Is there stagnation of refrigerant?} Q4 -- NO --> A3[Compressor lock → Replace] Q4 -- YES --> Q5{Does PMV operate correctly?} Q5 -- NO --> A4[TE, TS sensor, Check PMV. Defective → Replace] Q5 -- YES --> A5[Check outdoor P.C. board. Defect → Replace] </pre>

LED display legend: ● Go off, ○ Go on, ◎ Flash (5Hz)

<In case of SP40 to SP56>

Check code	APPLICATION CONTROL KIT LED display	Check / Countermeasures (Part without special mention indicates a part of the outdoor unit.)
[H03]	D01 (Red) (⊙) D02 (Yellow) (⊙) D03 (Yellow) (●) D04 (Yellow) (●)	<p>[Power supply error, Current detection circuit error]</p>
[L29]	D01 (Red) (○) D02 (Yellow) (●) D03 (Yellow) (●) D04 (Yellow) (○) or D01 (Red) (●) D02 (Yellow) (⊙) D03 (Yellow) (⊙) D04 (Yellow) (●)	<p>[Power supply error, Current detection circuit error]</p>
[P03]	D01 (Red) (●) D02 (Yellow) (○) D03 (Yellow) (○) D04 (Yellow) (●)	<p>[Discharge temp. error]</p>
[P04]	D01 (Red) (○) D02 (Yellow) (●) D03 (Yellow) (●) D04 (Yellow) (○)	<p>[Power supply error (Voltage error)]</p>
[P05]	D01 (Red) (⊙) D02 (Yellow) (⊙) D03 (Yellow) (●) D04 (Yellow) (●) or D01 (Red) (○) D02 (Yellow) (●) D03 (Yellow) (●) D04 (Yellow) (○)	<p>[Power supply error (Voltage error)] → Refer to columns [H03] and [P04] and then check power supply and voltage error.</p>

LED display legend: ● Go off, ○ Go on, ⊙ Flash (5Hz)

<In case of SP40 to SP56>

Check code	APPLICATION CONTROL KIT LED display	Check / Countermeasures (Part without special mention indicates a part of the outdoor unit.)
[P19]	—	<p>[4-way reversal error]</p> <pre> graph TD Q1{{Does 4-way valve work correctly? (Check pipe temperature, etc. during cooling/heating operation.)}} Q2{{Is coil of 4-way valve electrified during heating mode?}} Q3{{Is flow of refrigerant by PMV under correct conditions?}} Q4{{Check temperature sensors. TE sensor CN600, TS sensor CN603 Indoor TC sensor Defective → Correct or replace}} Q1 -- YES --> Q3 Q1 -- NO --> Q2 Q2 -- NO --> A1[Check outdoor P.C. board. Defect → Replace] Q2 -- YES --> A2[Check 4-way valve. Defect → Replace] Q3 -- YES --> Q4 Q3 -- NO --> A3[Check PMV. Defect → Replace] </pre> <p>* In case of SP40 to 56, the coil of 4-way valve is electrified during cooling cycling. * In cooling operation, [P19] error may be displayed when the refrigerant pressure rises high abnormally. In this case, remove the cause of pressure rising and then diagnose it again.</p>
[P22]	<p>D01 (Red) ○ D02 (Yellow) ○ D03 (Yellow) ○ D04 (Yellow) ●</p>	<p>[Outdoor fan system error]</p> <pre> graph TD Q1{{Is connection of connector CN300 correct?}} Q2{{After pulling out the connector of the fan motor CN300, rotate its shaft by hands. Can it rotate smoothly? Is the fan motor coil resistance within the range described below? Between red and white lead : 18 to 30Ω Between white and black lead : 18 to 30Ω Between black and red lead : 18 to 30Ω}} Q3{{Check outdoor P.C. board. Defective → Replace}} Q1 -- NO --> A1[Correct connection of connector.] Q1 -- YES --> Q2 Q2 -- NO --> A2[Fan motor exchange] Q2 -- YES --> Q3 </pre>
[P26]	<p>D01 (Red) ◎ D02 (Yellow) ● D03 (Yellow) ● D04 (Yellow) ●</p>	<p>[Short-circuit of compressor driving device]</p> <pre> graph TD Q1{{Is AC mains voltage correct? 198 to 264V}} Q2{{Is there any problem on connection of compressor lead or reactor? (Check connection referring to the wiring diagram.)}} Q3{{After disconnection of the compressor leads from P.C. board, the air conditioner operates in heating mode. Does the fan motor run?}} Q4{{Check compressor. (Rare short, etc.) Defective → Replace}} Q1 -- NO --> A1[Correct power line.] Q1 -- YES --> Q2 Q2 -- YES --> A2[Correct wiring.] Q2 -- NO --> Q3 Q3 -- NO --> A3[Replace outdoor P.C. board.] Q3 -- YES --> Q4 </pre>
[P29]	<p>D01 (Red) ● D02 (Yellow) ◎ D03 (Yellow) ● D04 (Yellow) ●</p>	<p>[Position detection circuit error]</p> <p>Check outdoor P.C. board. Defective → Replace</p>

LED display legend: ● Go off, ○ Go on, ◎ Flash (5Hz)

<In case of SP80>

8-2-4. Diagnostic Procedure for Each Check Code (Outdoor Unit)

- 1) This section describes the diagnostic method for each check code displayed on the wired remote controller.
- 2) In some cases, a check code indicates multiple symptoms.
In this case, confirm LED display on the outdoor P.C. board to narrow the contents to be confirmed.
- 3) The check code on the remote controller is displayed only when the same error occurred continuously by multiple times while LED of the outdoor P.C. board displays even an error which occurred once.
Therefore the display on the remote controller may differ from that of LED.

How to check LED display on outdoor P.C. board

Dip switch setup

- When turning on 1) only of SW803, the latest error is displayed. As the memory is stored, it can be confirmed even if the power supply is turned off once. (excluding outside temp. sensor (TO) error)
- When the work finished or the outdoor temp. sensor (TO) error was found, turn off all of SW803. (The error which occurs at present is displayed.)

<Latest error display>
Only 1) of SW803 is ON.

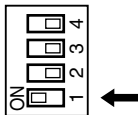

<Error display, which occurs at present>
All SW803 are OFF. (Initial status)

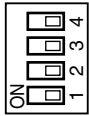

Display selection

- When an error happens, some of yellow LED (D800 to D804) turn on. **<Display 1>**
- If pushing the button switch SW800 for 1 second under the above condition, the yellow LED is displayed with flashing. **<Display 2>**
- When pushing SW800 for 1 second again, the status returns to **<Display 1>**.
- The error contents can be confirmed by combining **<Display 1>** and **<Display 2>**.

<Display 1> ↔ <Display 2>



	(No error)	(Error occurred)	(Push SW800)
D800 (Yellow)	●	○	●
D801 (Yellow)	●	○	●
D802 (Yellow)	●	●	◎
D803 (Yellow)	●	●	●
D804 (Yellow)	●	○	●
D805 (Green)	○	○	○

(Example of discharge temp. sensor error)
● : Go off, ○ : Go on, ◎ : Flash

Check code	Outdoor LED display	Check and troubleshooting (Item without special mention indicates part of outdoor unit.)
[E04]	—	<p>[Indoor/Outdoor communication error]</p> <pre> graph TD Q1{{Is setting of group address of remote controller correct?}} -- NO --> A1[Check Item code [14].] Q1 -- YES --> Q2{{Are inner wiring of indoor unit and inter-unit wires (1, 2, 3) correct?}} Q2 -- NO --> A2[Correct wiring and inter-unit cable.] Q2 -- YES --> Q3{{Are CN04 connection and wiring of terminal blocks (1, 2, 3) correct?}} Q3 -- NO --> A3[Correct wiring of connectors and terminal blocks.] Q3 -- YES --> Q4{{After turning off the power supply, turn on it again. Does D502 (Orange LED) flash?}} Q4 -- NO --> A4[Check indoor P.C. board. Defect → Replace] Q4 -- YES --> A5[Check outdoor P.C. board. Defect → Replace] </pre>

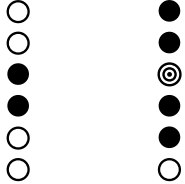
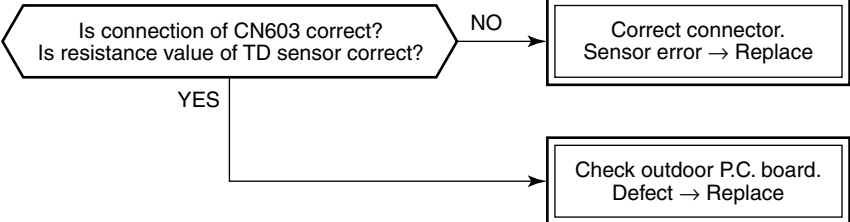
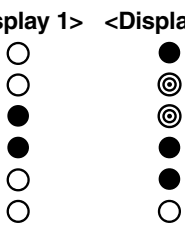
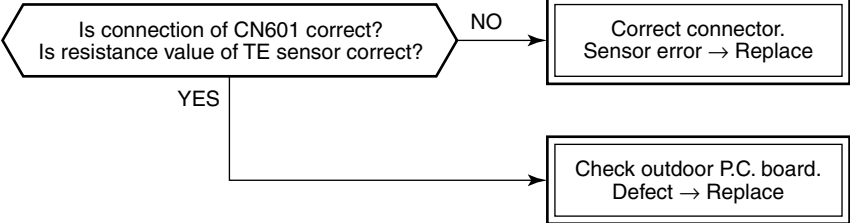
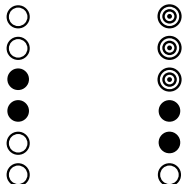
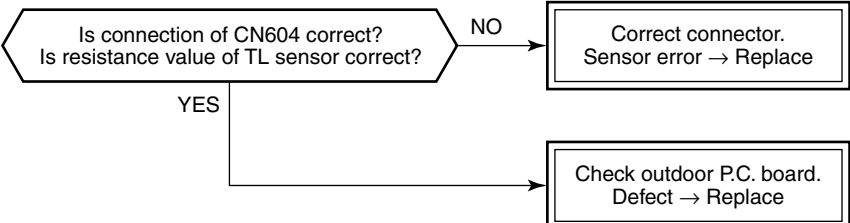
<In case of SP80>

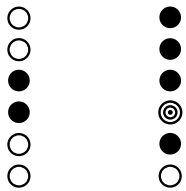
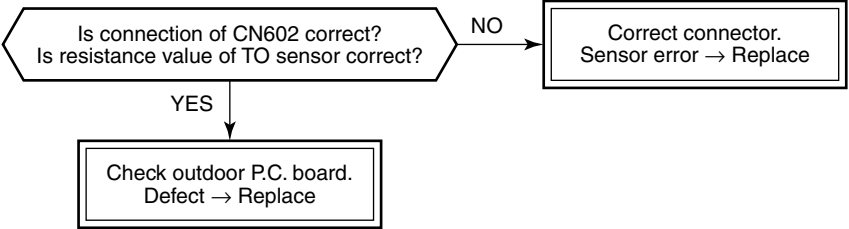
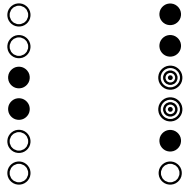
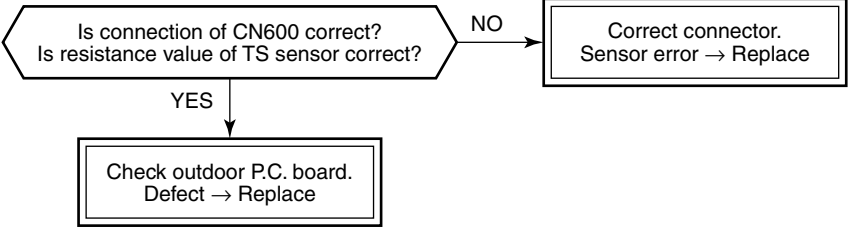
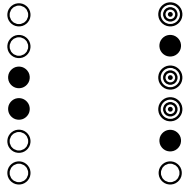
Check code	Outdoor LED display	Check and troubleshooting (Item without special mention indicates part of outdoor unit.)
[F04]	<p><Display 1> <Display 2></p> 	<p>[Discharge temp. sensor (TD) error]</p> 
[F06]	<p><Display 1> <Display 2></p> 	<p>• There is a possibility that it is one of the following errors. Confirm LED on outdoor P.C. board to judge which error it is. Heat exchanger temp. sensor (TE) error, Heat exchanger temp. sensor (TL) error, Suction temp. sensor (TS) error, Miswiring of heat exchanger sensor (TE, TS)</p> <p>[Heat exchanger temp. sensor (TE) error]</p>  <p>[Heat exchanger temp. sensor (TL) error] → Refer to [F07] column.</p> <p>[Suction temp. sensor (TS) error] → Refer to [F12] column.</p> <p>[Miswiring of heat exchanger sensor (TE, TS)] → Refer to [F15] column.</p>
[F07]	<p><Display 1> <Display 2></p> 	<p>[Heat exchanger temp. sensor (TL) error]</p> 

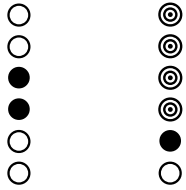
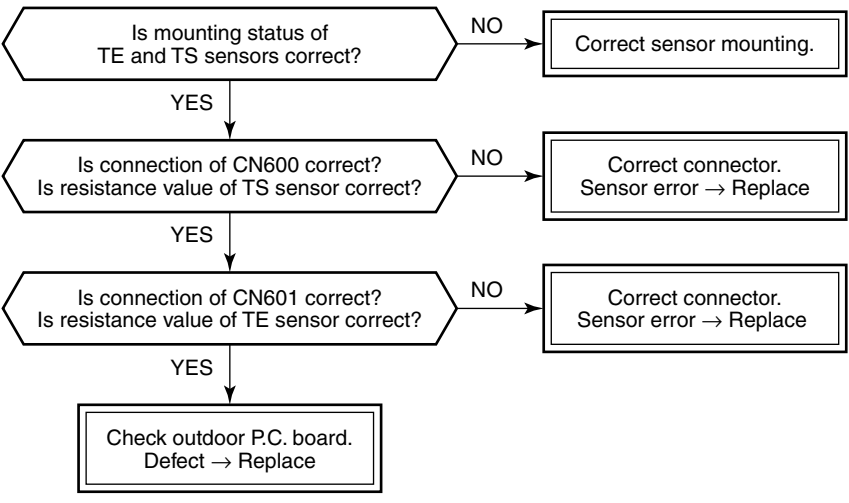
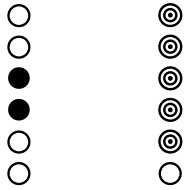
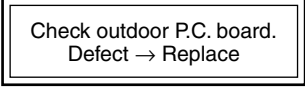
Check code	Outdoor LED display	Check and troubleshooting (Item without special mention indicates part of outdoor unit.)
[F08]	<Display 1> <Display 2> 	<p>[Outside temp. sensor (TO) error]</p> 
[F12]	<Display 1> <Display 2> 	<p>[Suction temp. sensor (TS) error]</p> 
[F13]	<Display 1> <Display 2> 	<p>[Heat sink temp. sensor (TH) error]</p> 
[F15]	<Display 1> <Display 2> 	<p>[Miswiring of heat exchanger sensor (TE, TS)]</p> 
[F31]	<Display 1> <Display 2> 	<p>[EEPROM error]</p> 

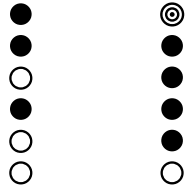
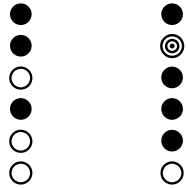
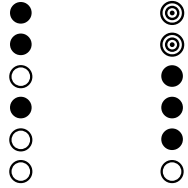
Check code	Outdoor LED display	Check and troubleshooting (Item without special mention Indicates part of outdoor unit.)
[H01]	<Display 1> <Display 2> 	<p>[Compressor break down]</p> <pre> graph TD Q1{{Is AC mains voltage correct? AC198 to 264V}} -- NO --> A1[Correct power supply line.] Q1 -- YES --> Q2{{Is wire connection correct? Compressor lead (Board side, Compressor side), Reactor lead, Power supply lead}} Q2 -- NO --> A2[Check wire connection and correct it.] Q2 -- YES --> Q3{{Does an abnormal overload happen?}} Q3 -- YES --> A3[Remove and improve the cause of overload.] Q3 -- NO --> A4[Check outdoor P.C. board. Defect → Replace] </pre>
[H02]	<Display 1> <Display 2> 	<p>[Compressor lock]</p> <pre> graph TD Q1{{Is AC mains voltage correct? AC198 to 264V}} -- NO --> A1[Correct power supply line.] Q1 -- YES --> Q2{{Is wire connection correct? Compressor lead (Board side, Compressor side), Reactor lead, Power supply lead}} Q2 -- NO --> A2[Check wire connection and correct it.] Q2 -- YES --> Q3{{Is compressor under correct conditions?}} Q3 -- YES --> A3[Check outdoor P.C. board. Defect → Replace] Q3 -- NO --> Q4{{Is there refrigerant stagnation?}} Q4 -- NO --> A4[Compressor lock → Replace] Q4 -- YES --> Q5{{Does PMV correctly operate?}} Q5 -- NO --> A5[Check TE, TS sensors and PMV. Defect → Replace] Q5 -- YES --> A6[Check outdoor P.C. board. Defect → Replace] </pre>
[H03]	<Display 1> <Display 2> 	<p>[Current detection circuit error]</p> <pre> graph TD A1[Check outdoor P.C. board. Defect → Replace] </pre>

<In case of SP80>

Check code	Outdoor LED display	Check and troubleshooting (Item without special mention Indicates part of outdoor unit.)
[H04]	<p><Display 1> <Display 2></p> <p>● ●</p> <p>● ●</p> <p>○ ⊙</p> <p>● ●</p> <p>○ ●</p> <p>○ ○</p>	<p>[Case thermostat operation]</p> <pre> graph TD Q1{Are CN609 connection and case thermostat correct?} -- NO --> A1[Correct connector. Case thermostat error → Replace] Q1 -- YES --> Q2{Short each pins of CN609. Can compressor operate?} Q2 -- NO --> A2[Check outdoor P.C. board. Defect → Replace] Q2 -- YES --> Q3{Is there gas leak? Is there refrigerant shortage?} Q3 -- YES --> A3[Repair defectives position. Recharge refrigerant.] Q3 -- NO --> Q4{Is service valve fully opened?} Q4 -- NO --> A4[Open service valve fully.] Q4 -- YES --> Q5{Is PMV under correct conditions?} Q5 -- NO --> A5[Correct defective position. Replace defective part.] Q5 -- YES --> A6[Check crushed or broken pipe. Defect → Correct and Replace] </pre>
[L10]	<p><Display 1> <Display 2></p> <p>● ●</p> <p>○ ⊙</p> <p>○ ●</p> <p>● ⊙</p> <p>○ ●</p> <p>○ ○</p>	<p>[Unset model type]: Only when service P.C. board is used</p> <div style="border: 1px solid black; padding: 5px; width: fit-content; margin: 10px auto;"> <p>Cut jumper line according to the explanation sheet packaged with the service P.C. board.</p> </div>

<In case of SP80>

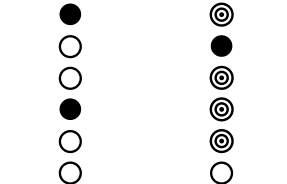
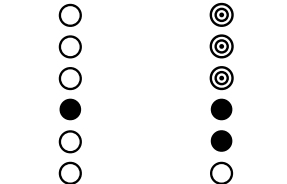
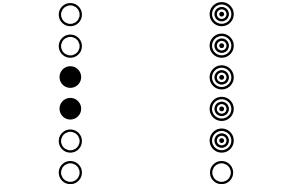
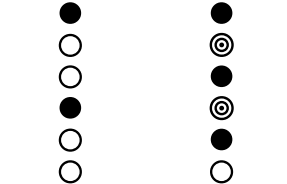
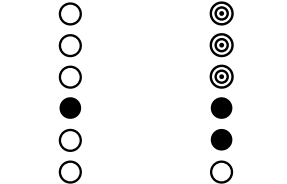
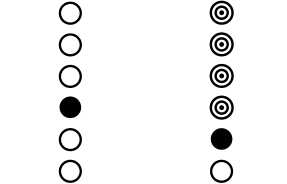
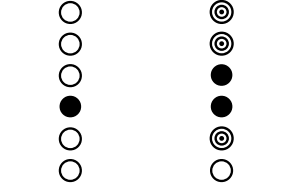
Check code	Outdoor LED display	Check and troubleshooting (Item without special mention Indicates part of outdoor unit.)
[L29]		* There is a possibility that it is one of the following errors. Confirm LED on outdoor P.C. board to judge which error it is. Communication error between MCU, Heat sink temp. sensor (TH) error, EEPROM error, Unset model type, Heat sink overheat error, Gas leak detection, 4-way valve inverse error
	<Display 1> <Display 2> 	[Communication error between MCUs] <div style="border: 1px solid black; padding: 5px; width: fit-content; margin: 10px auto;"> Check outdoor P.C. board. Defect → Replace </div>
	<Display 1> <Display 2> 	[Heat sink temp. sensor (TH) error] → Refer to [F13] column.
	<Display 1> <Display 2> 	[EEPROM error] → Refer to [F31] column.
	<Display 1> <Display 2> 	[Unset model type] → Refer to [L10] column.
	<Display 1> <Display 2> 	[Heat sink overheat error] → Refer to [P07] column.
	<Display 1> <Display 2> 	[Gas leak detection] → Refer to [P15] column.
	<Display 1> <Display 2> 	[4-way valve inverse error] → Refer to [P19] column.

<In case of SP80>

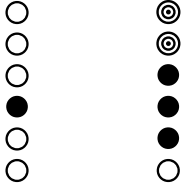
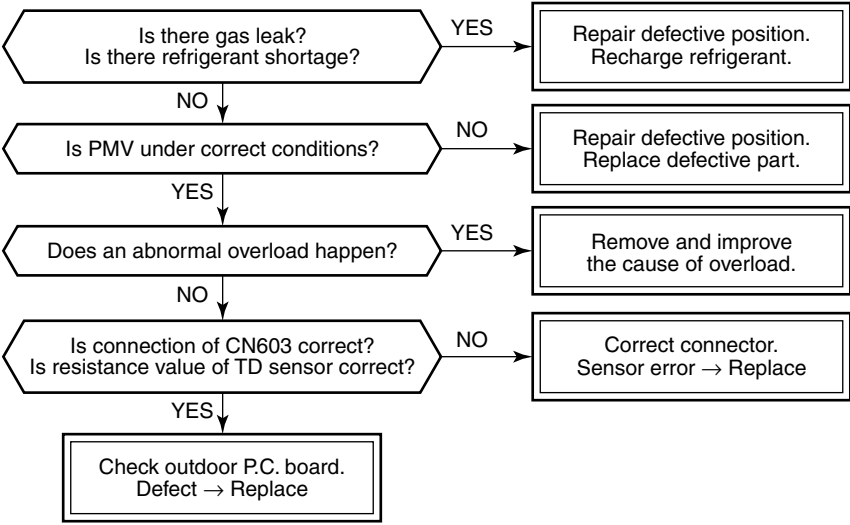
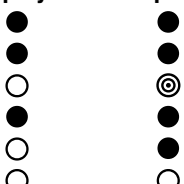
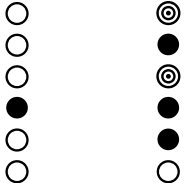
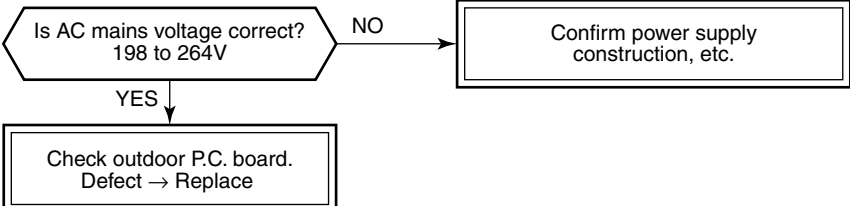
Check code	Outdoor LED display	Check and troubleshooting (Item without special mention indicates part of outdoor unit.)
[P03]	<Display 1> <Display 2> 	<p>[Discharge temp. error]</p> 
[P04]	<Display 1> <Display 2> 	<p>* There is a possibility that it is one of the following errors. Confirm LED on outdoor P.C. board to judge which error it is. Power supply error (Vdc), High pressure protective operation, Case thermostat operation</p> <p>[Case thermostat operation] → Refer to [H04] column.</p> <p>[Power supply error] → Refer to [P05] column.</p> <p>[High pressure protective operation] → Refer to [P20] column.</p>
[P05]	<Display 1> <Display 2> 	<p>[Power supply error]</p> 

Check code	Outdoor LED display	Check and troubleshooting (Item without special mention indicates part of outdoor unit.)
[P07]	<p><Display 1> <Display 2></p> <p>○ ◎</p> <p>○ ◎</p> <p>○ ◎</p> <p>● ●</p> <p>○ ○</p> <p>○ ○</p>	<p>[Heat sink overheat error]</p> <pre> graph TD Q1{{Are the power devices on P.C. board screwed without looseness? (Rear sides of Q201, Q300, Q650, DB01, DB02) Are radiation grease properly applied? (Q201, Q650, DB01, DB02)}} Q1 -- NO --> B1[Apply radiation grease to objective parts. Retightening of screws. (Be sure not to forget to attach insulating sheet between heat sink and Q300.)] Q1 -- YES --> Q2{{Does something block the ventilation around the heat sink? Does something block air flow from the fan?}} Q2 -- YES --> B2[Remove blocking matter. Correct short-circuit.] Q2 -- NO --> B3[Check outdoor P.C. board. Defect -> Replace] </pre>
[P15]	<p><Display 1> <Display 2></p> <p>○ ◎</p> <p>○ ◎</p> <p>○ ◎</p> <p>● ◎</p> <p>○ ○</p> <p>○ ○</p>	<p>[Gas leak detection]</p> <pre> graph TD Q1{{Is there gas leak? Is there refrigerant shortage?}} Q1 -- YES --> B1[Repair defective part. Recharge refrigerant.] Q1 -- NO --> Q2{{Is PMV under correct conditions?}} Q2 -- NO --> B2[Correct defective part. Replace defective part.] Q2 -- YES --> Q3{{Is service valve fully opened?}} Q3 -- NO --> B3[Open service valve fully.] Q3 -- YES --> Q4{{Is there crushed pipe?}} Q4 -- YES --> B4[Correct and replace piping.] Q4 -- NO --> Q5{{Check temp. sensor. TD sensor CN603 TS sensor CN600}} Q5 -- Error --> B5[Correct connector. Sensor error -> Replace] Q5 -- OK --> B6[Check outdoor P.C. board. Defect -> Replace] </pre>

Check code	Outdoor LED display	Check and troubleshooting (Item without special mention indicates part of outdoor unit.)				
[P19]	<p><Display 1> <Display 2></p> <p>○ ◎</p> <p>○ ◎</p> <p>○ ●</p> <p>● ●</p> <p>○ ◎</p> <p>○ ○</p>	<p>[4-way valve reversal error]</p> <p>Check method of outdoor P.C. board operation (Self-holding valve type)</p> <ol style="list-style-type: none"> Set SW804 of Dip switch as the following figure and then push SW801 for approx. 1 second to check exchange operation to cooling cycle/heating cycle. <ul style="list-style-type: none"> Power is turned on for approx. 10 seconds. In case of operating with the coil of 4-way valve connected to CN701, take interval over 1 minute before re-operation; otherwise it may cause overheat of the coil. After check, turn off all the Dip switch SW804. <table border="1" data-bbox="602 1311 1433 1632"> <thead> <tr> <th>Exchange to cooling cycle</th> <th>Exchange to heating cycle</th> </tr> </thead> <tbody> <tr> <td> </td> <td> </td> </tr> </tbody> </table> <p>Note) Check by tester Analog tester : Good if over DC200V Digital tester : Good if the maximum voltage is over DC200V though the varied voltage may be displayed.</p> <p>* In cooling operation, [P19] error may happen when the refrigerant pressure rose abnormally. In this case, remove the cause of pressure rising and then diagnose the error again.</p>	Exchange to cooling cycle	Exchange to heating cycle		
Exchange to cooling cycle	Exchange to heating cycle					

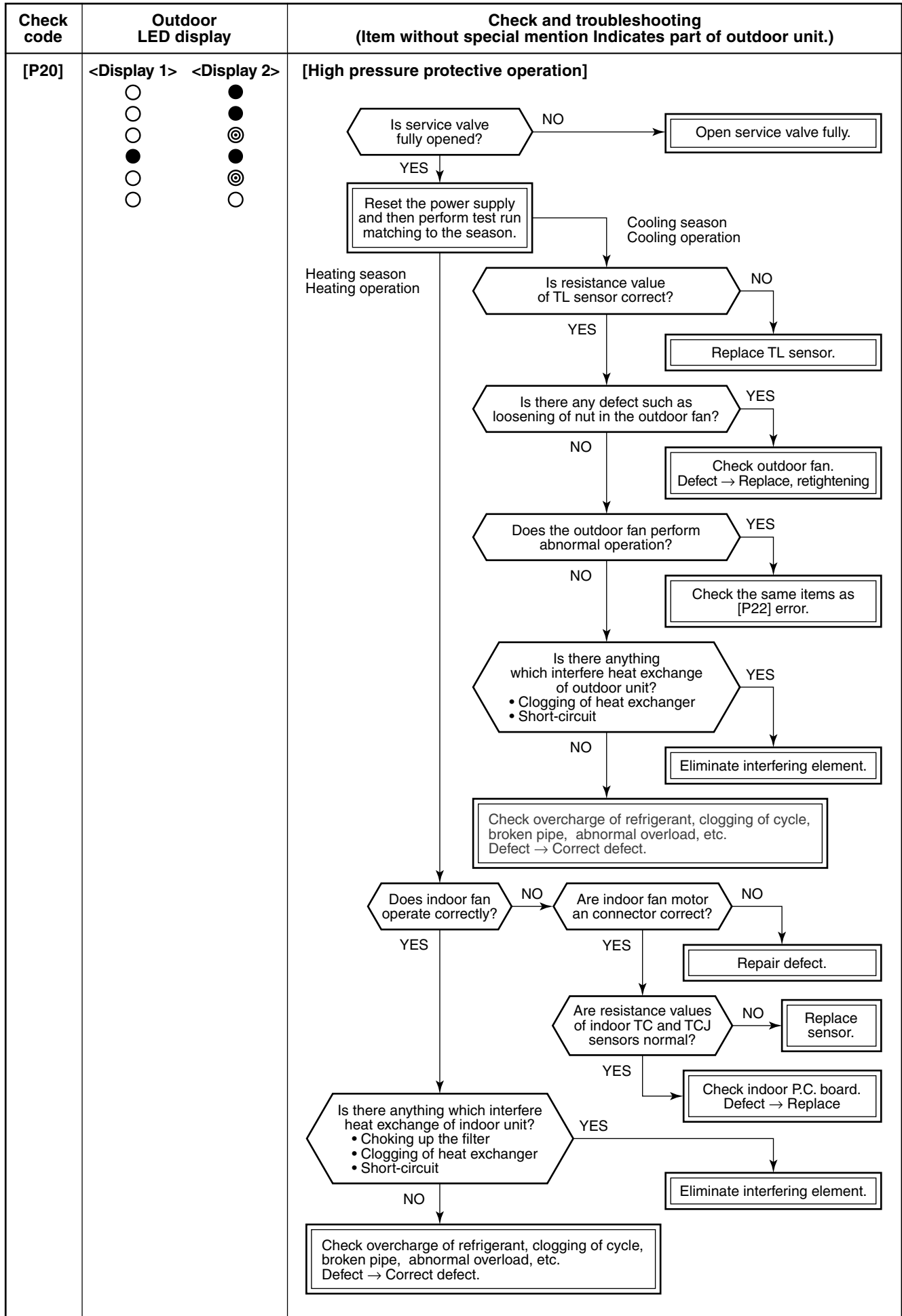

Check code	Outdoor LED display	Check and troubleshooting (Item without special mention indicates part of outdoor unit.)														
[P22]	<table border="0"> <tr> <td><Display 1></td> <td><Display 2></td> </tr> <tr> <td>○</td> <td>●</td> </tr> <tr> <td>○</td> <td>◎</td> </tr> <tr> <td>○</td> <td>◎</td> </tr> <tr> <td>●</td> <td>●</td> </tr> <tr> <td>○</td> <td>◎</td> </tr> <tr> <td>○</td> <td>○</td> </tr> </table>	<Display 1>	<Display 2>	○	●	○	◎	○	◎	●	●	○	◎	○	○	<p>[Fan system error]</p> <p>Single operation check for outdoor fan</p> <ol style="list-style-type: none"> Set Dip switch of SW804 as the following figure and then push SW801 for approx. 1 second to check single operation of outdoor fan. Use this method to check which fan, upper or lower fan, has a trouble. <ul style="list-style-type: none"> When SW801 is pushed for 1 second again or 2 minutes passed, the fan stops. After check, turn off all Dip switch of SW804. <div style="border: 1px solid black; padding: 5px; width: fit-content;"> <p>Outdoor fan single operation</p> </div>
<Display 1>	<Display 2>															
○	●															
○	◎															
○	◎															
●	●															
○	◎															
○	○															
[P26]	<table border="0"> <tr> <td><Display 1></td> <td><Display 2></td> </tr> <tr> <td>○</td> <td>●</td> </tr> <tr> <td>○</td> <td>◎</td> </tr> <tr> <td>○</td> <td>●</td> </tr> <tr> <td>●</td> <td>◎</td> </tr> <tr> <td>○</td> <td>◎</td> </tr> <tr> <td>○</td> <td>○</td> </tr> </table>	<Display 1>	<Display 2>	○	●	○	◎	○	●	●	◎	○	◎	○	○	<p>[Short-circuit of compressor drive element]</p>
<Display 1>	<Display 2>															
○	●															
○	◎															
○	●															
●	◎															
○	◎															
○	○															
[P29]	<table border="0"> <tr> <td><Display 1></td> <td><Display 2></td> </tr> <tr> <td>○</td> <td>◎</td> </tr> <tr> <td>○</td> <td>●</td> </tr> <tr> <td>○</td> <td>◎</td> </tr> <tr> <td>●</td> <td>◎</td> </tr> <tr> <td>○</td> <td>◎</td> </tr> <tr> <td>○</td> <td>○</td> </tr> </table>	<Display 1>	<Display 2>	○	◎	○	●	○	◎	●	◎	○	◎	○	○	<p>[Position detection circuit error]</p> <div style="border: 1px solid black; padding: 5px; width: fit-content;"> <p>Check outdoor P.C. board. Defect → Replace</p> </div>
<Display 1>	<Display 2>															
○	◎															
○	●															
○	◎															
●	◎															
○	◎															
○	○															
— No code	<table border="0"> <tr> <td><Display 1></td> <td><Display 2></td> </tr> <tr> <td>●</td> <td>◎</td> </tr> <tr> <td>○</td> <td>◎</td> </tr> <tr> <td>○</td> <td>◎</td> </tr> <tr> <td>○</td> <td>◎</td> </tr> <tr> <td>○</td> <td>◎</td> </tr> <tr> <td>○</td> <td>○</td> </tr> </table>	<Display 1>	<Display 2>	●	◎	○	◎	○	◎	○	◎	○	◎	○	○	<p>[Other error] Compressor disorder due to sudden change of load, etc.</p> <ul style="list-style-type: none"> * Although the display of outdoor LED outputs, the unit automatically restarts and error is not determined. * LED display also may output due to wire coming-off of compressor.
<Display 1>	<Display 2>															
●	◎															
○	◎															
○	◎															
○	◎															
○	◎															
○	○															

8-2-5. Diagnostic Procedure for Each Check Code (Outdoor Unit)

Temperature sensor Temperature – Resistance value characteristic table

TA, TC, TCJ, TE, TS, TO sensors

TD, TL sensors

Representative value

Representative value

Temperature (°C)	Resistance value (kΩ)		
	(Minimum value)	(Standard value)	(Maximum value)
0	32.33	33.80	35.30
10	19.63	20.35	21.09
20	12.23	12.59	12.95
25	9.75	10.00	10.25
30	7.764	7.990	8.218
40	5.013	5.192	5.375
50	3.312	3.451	3.594
60	2.236	2.343	2.454
70	1.540	1.623	1.709
80	1.082	1.146	1.213
90	0.7740	0.8237	0.8761
100	0.5634	0.6023	0.6434

Temperature (°C)	Resistance value (kΩ)		
	(Minimum value)	(Standard value)	(Maximum value)
0	150.5	161.3	172.7
10	92.76	99.05	105.6
20	58.61	62.36	66.26
25	47.01	49.93	52.97
30	37.93	40.22	42.59
40	25.12	26.55	28.03
50	17.00	17.92	18.86
60	11.74	12.34	12.95
70	8.269	8.668	9.074
80	5.925	6.195	6.470
90	4.321	4.507	4.696
100	3.205	3.336	3.468

TA, TC, TCJ, TE, TS, TO sensors

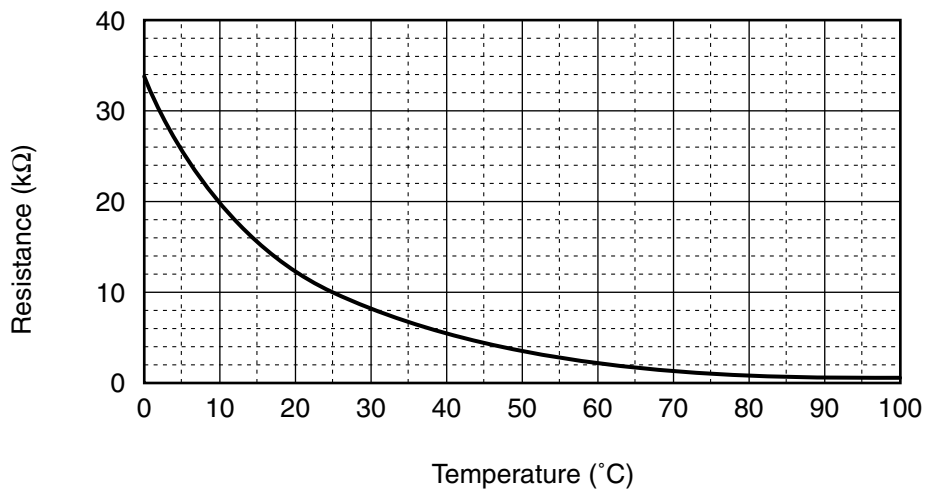

TD, TL sensors

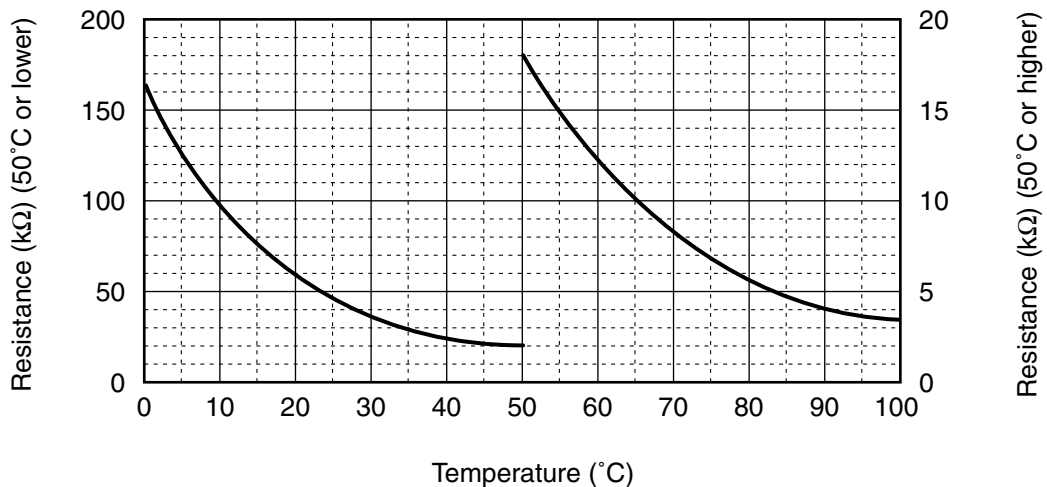

* As TH sensor (Outdoor unit heat sink temp. sensor) is incorporated in the outdoor control P.C. board, the resistance value cannot be measured.

8-3. Table Inspection of outdoor unit main parts

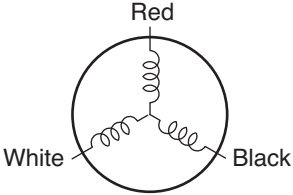
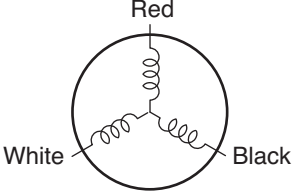
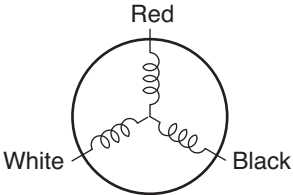
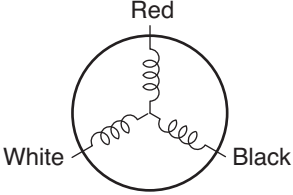
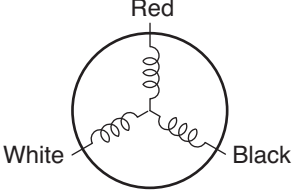
No.	Parts name	Checking procedure						
1	Compressor (Model : DA150A1F-20F)	<p>Measure the resistance value of each winding by using the tester.</p>  <table border="1" data-bbox="967 332 1451 569"> <thead> <tr> <th>Position</th> <th>Resistance value</th> </tr> </thead> <tbody> <tr> <td>Red – White</td> <td rowspan="3">0.93 Ω</td> </tr> <tr> <td>White – Black</td> </tr> <tr> <td>Black – Red</td> </tr> </tbody> </table> <p style="text-align: right;">Under 20°C</p>	Position	Resistance value	Red – White	0.93 Ω	White – Black	Black – Red
Position	Resistance value							
Red – White	0.93 Ω							
White – Black								
Black – Red								
2	Compressor (Model : DA150A1F-21F)	<p>Measure the resistance value of each winding by using the tester.</p>  <table border="1" data-bbox="967 707 1451 943"> <thead> <tr> <th>Position</th> <th>Resistance value</th> </tr> </thead> <tbody> <tr> <td>Red – White</td> <td rowspan="3">1.07 Ω</td> </tr> <tr> <td>White – Black</td> </tr> <tr> <td>Black – Red</td> </tr> </tbody> </table> <p style="text-align: right;">Under 20°C</p>	Position	Resistance value	Red – White	1.07 Ω	White – Black	Black – Red
Position	Resistance value							
Red – White	1.07 Ω							
White – Black								
Black – Red								
3	Compressor (Model : DA220A2F-22L)	<p>Measure the resistance value of each winding by using the tester.</p>  <table border="1" data-bbox="967 1074 1451 1311"> <thead> <tr> <th>Position</th> <th>Resistance value</th> </tr> </thead> <tbody> <tr> <td>Red – White</td> <td rowspan="3">0.606 Ω</td> </tr> <tr> <td>White – Black</td> </tr> <tr> <td>Black – Red</td> </tr> </tbody> </table> <p style="text-align: right;">Under 20°C</p>	Position	Resistance value	Red – White	0.606 Ω	White – Black	Black – Red
Position	Resistance value							
Red – White	0.606 Ω							
White – Black								
Black – Red								
4	Fan motor (Model : ICF-140-43-4R)	<p>Measure the resistance value of each winding by using the tester.</p>  <table border="1" data-bbox="967 1448 1451 1685"> <thead> <tr> <th>Position</th> <th>Resistance value</th> </tr> </thead> <tbody> <tr> <td>Red – White</td> <td rowspan="3">21.00±1.05 Ω</td> </tr> <tr> <td>White – Black</td> </tr> <tr> <td>Black – Red</td> </tr> </tbody> </table> <p style="text-align: right;">Under 20°C</p>	Position	Resistance value	Red – White	21.00±1.05 Ω	White – Black	Black – Red
Position	Resistance value							
Red – White	21.00±1.05 Ω							
White – Black								
Black – Red								
5	Fan motor (Model : ICF-280-A60-1)	<p>Measure the resistance value of each winding by using the tester.</p>  <table border="1" data-bbox="967 1823 1451 2059"> <thead> <tr> <th>Position</th> <th>Resistance value</th> </tr> </thead> <tbody> <tr> <td>Red – White</td> <td rowspan="3">32.6±3.3 Ω</td> </tr> <tr> <td>White – Black</td> </tr> <tr> <td>Black – Red</td> </tr> </tbody> </table> <p style="text-align: right;">Under 20°C</p>	Position	Resistance value	Red – White	32.6±3.3 Ω	White – Black	Black – Red
Position	Resistance value							
Red – White	32.6±3.3 Ω							
White – Black								
Black – Red								

9. OTHERS

9-1. Refrigerant Recovery Control

The “ozone destruction coefficient” of HFC refrigerant is 0 and the discharge regulation is set as anathermal effect gas.

To this model, a switch which can perform the refrigerant recovery (pump down) by the outdoor unit is mounted so that it is easy to react against the environment at reinstalling or rejection time.

[Operation method]

<SP40 to SP56>

- 1) See the mode of the indoor unit to fan mode.
- 2) Push the refrigerant recovery switch (SW802) of the outdoor unit for approx. 2 seconds.
The cooling operation starts. (This operation finishes after 10 minutes.)
- 3) After operation for 3 minutes or more, close the valve at liquid side.
- 4) After recovering refrigerant, close the valve at gas side.
- 5) When keeping pushed the refrigerant recovery SW again for approx. 2 seconds, the outdoor unit stops.
- 6) Stop the indoor unit and then turn off the power supply.

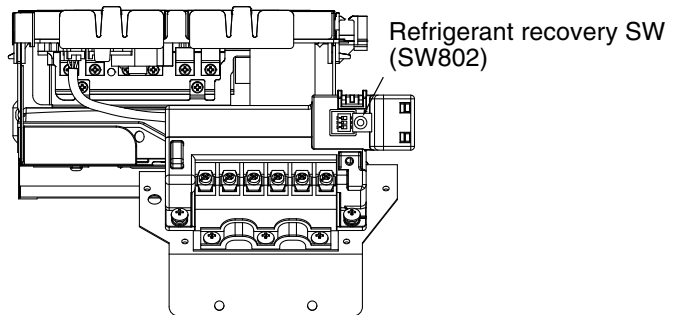
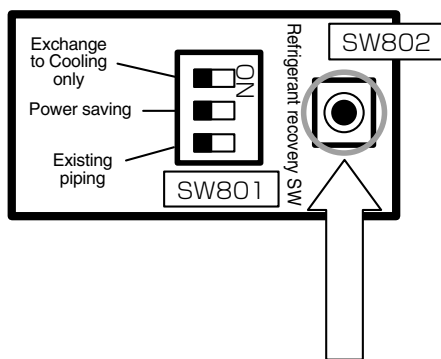

NOTE

The electric portion of the refrigerant recovery SW on the sub-board is electrified, therefore be careful to an electric shock.

<SP80>

- 1) Set the mode of the indoor unit to fan mode.
- 2) Set all DIP switch SW804 to OFF (Initial status) and then push the button switch SW801 for approx. 1 second.
The cooling operation starts.
(During this time, D805 (Green LED) flashes.)
This operation finishes by 10 minutes.
- 3) After operation for 3 minutes or more, close valve at liquid side.
- 4) After recovery of refrigerant, close valve at gas side.
- 5) Push the button switch SW801 again for approx. 1 second.
The outdoor unit stops.
- 6) Stop the indoor unit and then turn off the power supply.

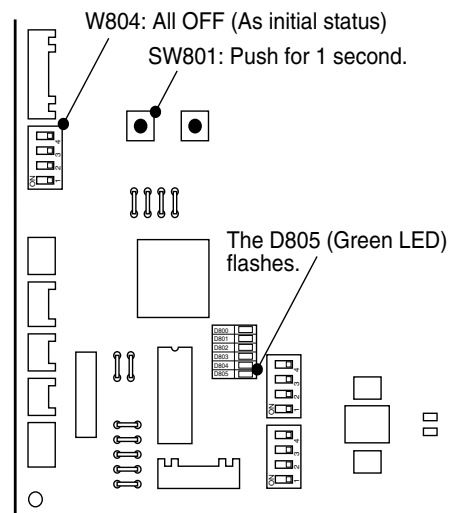

9-2. Various Setting on Outdoor Unit (Existing piping, Power save, Cooling-only, etc.)

The following settings are available by DIP switch setup and jumper line setup.

<SP40 to SP56>

Function	Setting position	Control contents
Existing piping setup		Turn off the switches. (Ø19.1 existing pipes cannot be used.)
Power save setup		When using the power saving function, turn on switches. The control to lower the compressor frequency (approx. -10%) is performed by indoor heat exchanger temp. in heating operation.
Cooling-only setup		When using the outdoor unit as a cooling-only machine, turn on switches. ("OF" of DN cord on the remote controller also can be used for changing the machine to the cooling-only model.)

<SP80>

Function	Set position	Control contents
High static pressure setup	<p>* all are OFF at shipment.</p>	Turn the switch to ON when mounting a duct to the discharge port of the outdoor unit. Add 3 taps to the upper limit value of the outdoor fan tap. The operation is performed with (Max: Upper fan: 890 rpm / Lower fan: 910 rpm (WF)). In this case, the upper limit value of static pressure for duct is 5Pa or less on 25°C degrees and please use straight duct. In this case, the outdoor noise level may increase.
Existing piping setup		Turn the switch to ON when Ø19.1 is used for the existing pipe. In this case, the heating capacity may lower according to outside temp. and indoor temp. in heating operation.
Power save setup		Turn the switch to ON when using the power save function. The control to lower the compressor frequency (Approx. -10%) is performed by indoor heat exchanger temp. in heating operation.
Snow-proof fan control		When snow enters from clearance of the fan guard or heat exchanger into blast path and it is accumulated, the control to prevent generation of motor lock is validated. When outside temp. is below 0°C though the compressor stops, the outdoor fan operates with W5.
Defrost time change		J805, J806
Max. frequency change	J807	When it is needed to lower the maximum value of the compressor frequency, cut the jumper line. Max. frequency at cooling/heating is lowered. In this case the Max. capacity decreases. Max. frequency of compressor
Cooling-only setup	J808	When using the air conditioner as a cooling-only conditioner, cut the jumper line. (An air conditioner can be changed to cooling-only conditioner by "OF" of DN code on the remote controller.)

Model	RAV-SP80	
	COOL	HEAT
Standard status	72.0	99.6
When J807 is cut	72.0	79.2

9-3. Service Support Function (LED Display, Switch Operation)

<SP80 only>

1. Outline

A various setup and operation check can be performed by DIP switches at 3 positions (SW802, SW803, SW804) and the pushdown button switches (SW800, SW801) at 2 positions.

Operation part

Part No.	Specifications	Operation contents
SW800	Pushdown button switch	Exchanges the displayed contents of LED (D800 to D804) on the outdoor control P.C. board.
SW803	DIP switch	
SW801	Pushdown button switch	Performs the specific operation to check maintenance.
SW804	DIP switch	
SW802	DIP switch	Performs various initial settings. (Refer to 9-2.)

Display part

Part No.	Specifications	Operation contents
D502	Orange LED	Indoor/Outdoor communication (Serial communication) signal display (Receive signal from indoor signal)
D503	Green LED	Indoor/Outdoor communication (Serial communication) signal display (Send signal from outdoor signal)
D800 to D804	Yellow LED	Error display When all SW803 are OFF, or when any of D800 to D804 goes on, LED displays that the outdoor controller detects an error. When status of SW803 is other than OFF, various indications are displayed.
D805	Green LED	Power-ON display When the power of the outdoor unit is turned on, LED goes on. When SW801 and SW804 operate the specific operation, LED flashes.

* All LED are colorless when it goes off.

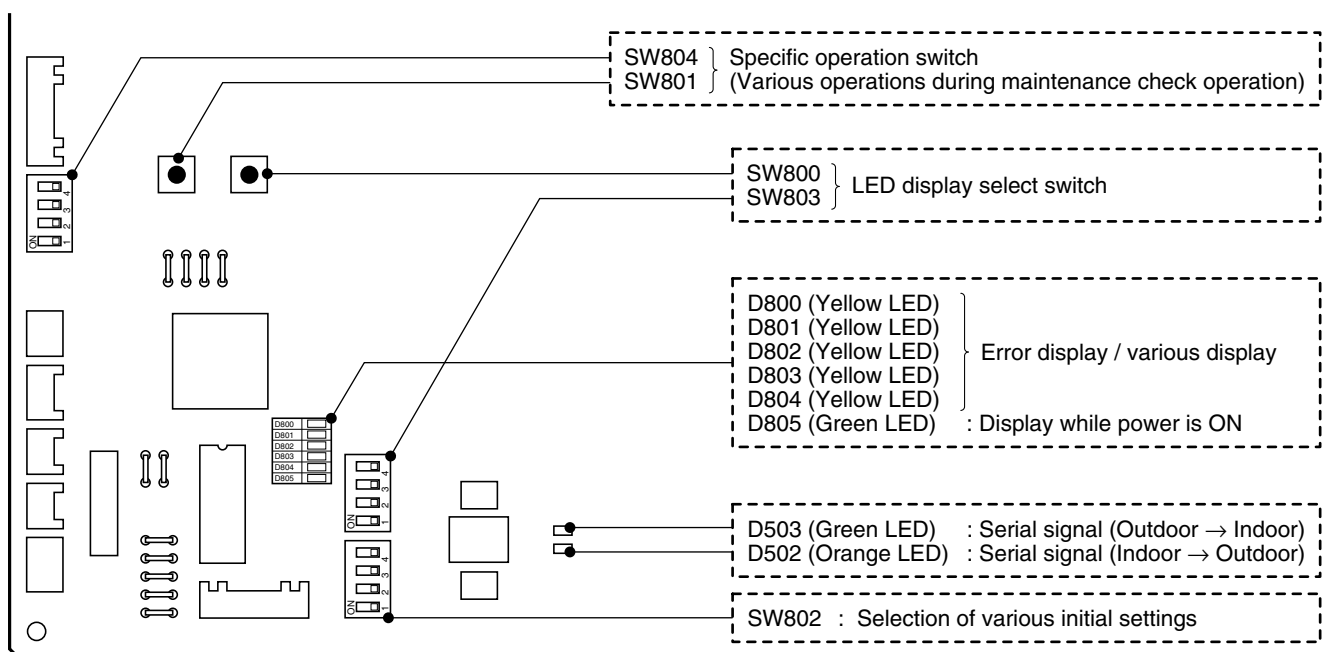

2. Selection of LED display (SW800, SW803 operation)

1) Display selection list

The displayed contents of LED D800 to D804 on the outdoor control P.C. board can be exchanged by operation of SW803.

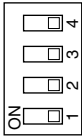
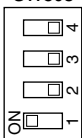
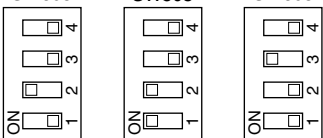
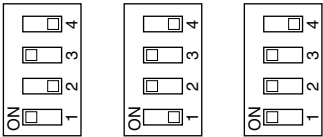
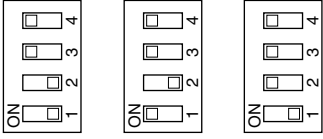
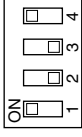
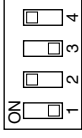
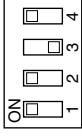
Switch	Function / Contents	Refer
<p>SW803</p> 	<p>Error display (Error generating at present) Error generating at present is displayed. This switch goes off when an error does not generate.</p>	<p>Refer to Page 79.</p>
<p>SW803</p> 	<p>Error display (The latest error: Latest error including present) After error status was cleared, the error which generated before can be confirmed by this setting. (Reconfirmation is available even if power supply was turned off once.)</p> <ul style="list-style-type: none"> • If an error generates at present, the same contents as those of error which is generating at present are displayed. • Only error of TO sensor is not displayed by this setting. (Confirm it by setting of error which is generating at present.) 	<p>Refer to Page 79.</p>
<p>TD SW803 TE SW803 TS SW803</p>  <p>TO SW803 TL SW803 TH SW803</p>  <p>TA SW803 TC SW803 TCJ SW803</p> 	<p>Temperature sensor display The detected value of temperature sensor is displayed.</p>	<p>Refer to Page 80.</p>
<p>SW803</p> 	<p>Current display The current value which flows in the outdoor unit is displayed.</p>	<p>Refer to Page 80.</p>
<p>SW803</p> 	<p>Compressor operation frequency display The operation frequency of the compressor is displayed.</p>	<p>Refer to Page 80.</p>
<p>SW803</p> 	<p>PMV opening display The opening of PMV (Pulse Motor Valve) is displayed.</p>	<p>Refer to Page 80.</p>

2) Error display

The error which is generating at present and the latest error (Latest error information including present) can be confirmed by lighting LED D800 to D804 on the outdoor control P.C. board.

- When all DIP switch SW803 are OFF, the status of error which is generating at present is displayed.
- <1> only of DIP switch SW803 is turned on, the error which generated before (Latest error information including present) is displayed
- If there is an error, any of LED D800 to D804 goes on. (Display 1)
- When pushing the pushdown button switch SW800 for approx. 1 second, the display is exchanged. (Display 2)
- When pushing SW800 again or after 2 minutes, the status returns to that of Display ①.

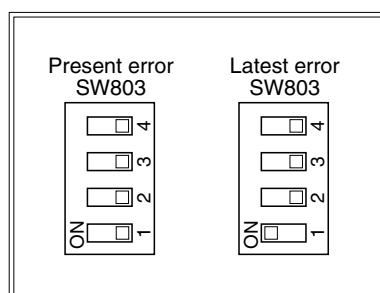

(Legend)	
●	D800 (Yellow)
●	D801 (Yellow)
◎	D802 (Yellow)
●	D803 (Yellow)
●	D804 (Yellow)
○	D805 (Green)

● : Go off, ○ : Go on, ◎ : Flash

Display 1) (Initial display)	Display 2) (SW800 operation)	Error contents	Wired remote controller Error code
●●●●●○	●●●●●○	Normal	—
○○●●○○	●●◎●●○	Discharge temp. sensor (TD) error	F04
	●◎◎●●○	Heat exchanger temp. sensor (TE) error	F06
	◎◎◎●●○	Heat exchanger temp. sensor (TL) error	F06, F07
	●●●◎●○	Outside temp. sensor (TO) error	F08
	●●◎◎●○	Suction temp. sensor (TS) error	F06, F12
	◎●◎◎●○	Heat sink temp. sensor (TH) error	F13, L29
	◎◎◎◎●○	Heat exchanger sensor (TE, TS) miswiring	F06, F15
	◎◎◎◎◎○	EEPROM error	F31, L29
●●○○●○○	◎●●●●○	Compressor break down	H01
	●◎●●●○	Compressor lock	H02
	◎◎●●●○	Current detection circuit error	H03
	●●◎●●○	Case thermostat operation	H04, P04
●○○●○○	●◎●◎●○	Model unset	L10, L29
	◎●◎◎◎○	Communication error between MCU	L29
	◎◎◎◎◎○	Other error (Compressor disorder, etc.)	Error is not determined.
○○○●○○	◎◎●●●○	Discharge temp. error	P03
	◎●◎●●○	Power supply error	P04, P05
	◎◎◎●●○	Heat sink overheat error	P07, L29
	◎◎◎◎●○	Gas leak detection	P15, L29
	◎◎●●◎○	4-way valve reverse error	P19, L29
	●●◎●◎○	High pressure protective operation	P04, P20
	●◎◎●◎○	Fan system error	P22
	●◎●◎◎○	Driving element short-circuit	P26
	◎●◎◎◎○	Position detection circuit error	P29

* As the error code displayed on the wired remote controller may differ according to type of indoor model, multiple codes are described.

3) Sensor, current, compressor operation frequency, PMV opening display

The values detected by the controller, such as temperature sensor or current value are simply confirmed.

(Legend)		
● D800 (Yellow)	● D803 (Yellow)	● : Go off, ○ : Go on
● D801 (Yellow)	● D804 (Yellow)	
● D802 (Yellow)	○ D805 (Green)	

Item setup LED display	Temperature sensor (°C)					Current (A)	Compressor operation frequency (rpm)	PMV opening (Pulse)
	TD SW803	TE SW803	TS SW803	TO SW803	TL SW803			
●●●●●○	Below -25					0 to 0.9	0 to 4	0 to 19
○●●●●○	-25 to -21					1 to 1.9	5 to 9	20 to 39
●○●●●○	-20 to -16					2 to 2.9	10 to 14	40 to 59
○○●●●○	-15 to -11					3 to 3.9	15 to 19	60 to 79
●●○●●○	-10 to -5					4 to 4.9	20 to 24	80 to 99
○●○●●○	-5 to -1					5 to 5.9	25 to 29	100 to 119
●○○●●○	0 to 4					6 to 6.9	30 to 34	120 to 139
○○○●●○	5 to 9					7 to 7.9	35 to 39	140 to 159
●●●○●○	10 to 14					8 to 8.9	40 to 44	160 to 179
○●●○●○	15 to 19					9 to 9.9	45 to 49	180 to 199
●○●○●○	20 to 24					10 to 10.9	50 to 54	200 to 219
○○●○●○	25 to 29					11 to 11.9	55 to 59	220 to 239
●●○○●○	30 to 34					12 to 12.9	60 to 64	240 to 259
○●○○●○	35 to 39					13 to 13.9	65 to 69	260 to 279
●○○○●○	40 to 44					14 to 14.9	70 to 74	280 to 299
○○○○●○	45 to 49					15 to 15.9	75 to 79	300 to 319
●●●●○○	50 to 54					16 to 16.9	80 to 84	320 to 339
○●●●○○	55 to 59					17 to 17.9	85 to 89	340 to 359
●○●●○○	60 to 64					18 to 18.9	80 to 84	360 to 379
○○●●○○	65 to 69					19 to 19.9	95 to 99	380 to 399
●●○●○○	70 to 74					20 to 20.9	100 to 104	400 to 419
○●○●○○	75 to 79					21 to 21.9	105 to 109	420 to 439
●○○●○○	80 to 84					22 to 22.9	110 to 114	440 to 459
○○○●○○	85 to 89					23 to 23.9	115 to 119	460 to 479
●●●○○○	90 to 94					24 to 24.9	120 to 124	480 to 499
○●●○○○	95 to 99					25 to 25.9	125 to 129	500
●○●○○○	100 to 104					26 to 26.9	130 to 134	—
○○●○○○	105 to 109					27 to 27.9	135 to 139	—
●●○○○○	110 to 114					28 to 28.9	140 to 144	—
○●○○○○	115 to 119					29 to 29.9	145 to 149	—
●○○○○○	Over 120					30 to 30.9	150 to 154	—
○○○○○○	Sensor error, unconnected					Over 31	Over 155	—

* As TD, TL and TH are sensors for high temperature, there is error at normal temperature or below position.

* For current value, the current for the outdoor unit only is displayed.

4) Specific operation for maintenance check (SW801, SW804)

The following specific operations for the maintenance check are performed by operation of SW801 or SW804.

- a) Select DIP switch SW804. (See table below)
- b) Push the pushdown button switch SW801 for approx. 1 second.
- c) The following functions start. While each function starts, LED D805 (Green) flashes.
- d) When pushing the pushdown button switch SW801 again for approx. 1 second, when selecting DIP switch SW804 or when the specified time of each function elapsed, each function stops and LED D805 (Green) returns to the continuous lighting.

<Specific operation>

SW804	Operation when pushdown button switch SW801 is pushed	
	Refrigerant recovery operation The outdoor unit performs cooling operation. The indoor unit does not work by this operation alone. Therefore operate the fan beforehand. (Refer → 9-1. Refrigerant Recovery Control)	
	Indoor cooling test run demand The cooling test run is performed. (→ Note 1)	
	Indoor heating test run demand The heating test run is performed. (→ Note 1)	
	Fan motor forced operation Drive the fan motor forcedly. When pushing SW801 again or when 2 minutes elapsed, the operation returns to the normal control.	
	(No operation especially)	[NOTE] Although these operations can be performed even during operation, basically perform operation while the unit stops. If performing this operation during driving the unit, it is dangerous because the pressure may change suddenly.
	PMV full open operation Open PMV (Pulse Motor Valve) fully. When pushing SW801 again or when 2 minutes elapsed, the operation returns to the normal control.	
	PMV full close operation Close PMV (Pulse Motor Valve) fully. When pushing SW801 again or when 2 minutes elapsed, the operation returns to the normal control.	
	PMV middle opening operation Set PMV (Pulse Motor Valve) to middle opening (250 pulses). When pushing SW801 again or when 2 minutes elapsed, the operation returns to the normal control.	

Note 1) Indoor cooling test run demand / Indoor heating test run demand

Only when combining with the following indoor unit, cooling/heating operation can be performed from the outdoor unit.

Test run is available: Indoor unit of 4 series and after (RAV-SM***4UTP* etc.)

Test run is unavailable: Indoor units other than the above-mentioned indoor units, or indoor units other than above-mentioned indoor units are included in the twin connection.

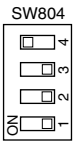
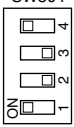
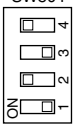
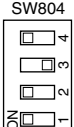
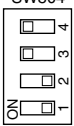
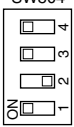
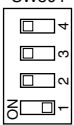
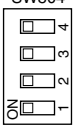

Note 2) The forced test run by this setting cannot be cleared on the indoor remote controller.

Be sure to clear the test run by operation of the outdoor unit. (Push SW801 again for 1 second.)





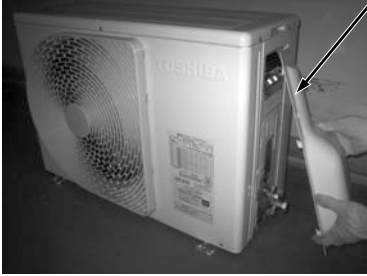

SW804	Operation when pushdown button switch SW801 is pushed	
	<p>4-way valve relay operation (For RY700, CN70 check) Turn on 4-way valve power relay (RY700). When pushing SW801 again or when 2 minutes elapsed, the operation returns to the normal control.</p> <p>[NOTE] In case of model adopting the self hold valve (RAV-SP1104AT-E, RAV-SP1404AT-E), the coil develops fever. Therefore do not perform this operation as coil is connected.</p>	
	<p>Self-hold valve suction operation (Exchange to heating cycle) (For RY700 RY701, RY705, CN701 check) Turn on relay RY700, RY701, RY705. (CN701 between ① and ④ : Voltage=Approx. +198 to 380V) This function works for 10 seconds and then is OFF.</p>	
	<p>Self-hold valve separation operation (Exchange to cooling cycle) Turn on relay RY700. (CN701 between 1) and 4): Voltage=Approx. -198 to 380V) This function works for 10 seconds and then is OFF.</p>	
	<p>SV valve relay operation (For RY702, CN702 check) Turn on SV valve relay (RY702). When pushing SW801 again or when 2 minutes elapsed, the operation returns to the normal control. * For RAV-SP1104AT-E to RAV-SP1404AT-E, the part is not mounted, so do not operate.</p>	<p>[CAUTION] Although these operations can be performed even during operation, basically perform operation while the unit stops. If performing this operation during driving the unit, it is dangerous because the pressure may change suddenly.</p>
	<p>Heater output relay operation (For check RY703, CN703 check) Turn on relay for option heater (RY703). When pushing SW801 again or when 2 minutes elapsed, the operation returns to the normal control.</p>	
	<p>Outside output relay operation (RY704, CN704) Turn on relay for outside output (RY704). When pushing SW801 again or when 2 minutes elapsed, the operation returns to the normal control.</p>	
	<p>(No operation especially)</p>	
	<p>Relay operation change for outside output [CAUTION] Do not use this setting.</p>	

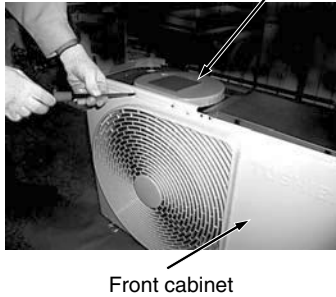
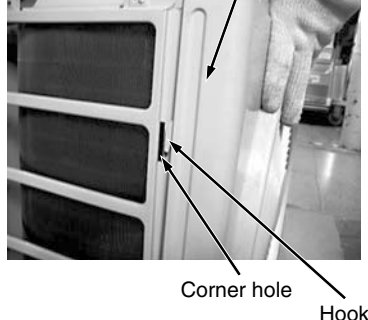
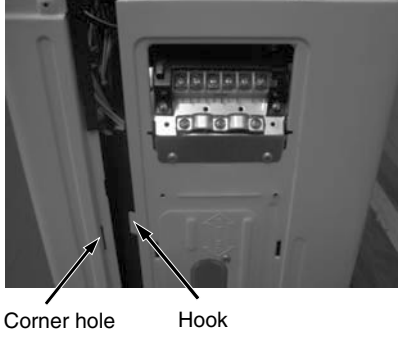

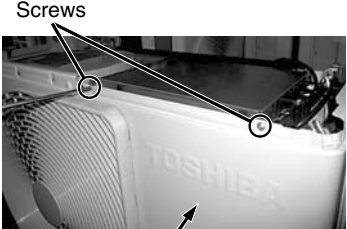
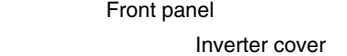
10. DETACHMENTS

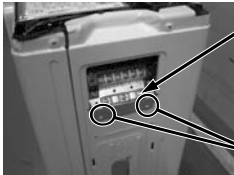



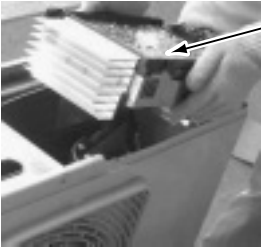

10-1. RAV-SP40*ATP*, SP45*ATP*, SP56*ATP*

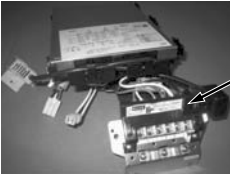
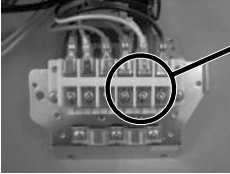

No.	Part name	Procedure	Remarks
①	Common procedure	<p style="text-align: center;">CAUTION</p> <p>Never forget to put on the gloves at working time, otherwise an injury will be caused by the parts, etc.</p> <hr/> <p>1. Detachment</p> <ol style="list-style-type: none"> 1) Stop operation of the air conditioner, and turn off the main switch of the breaker for air conditioner. 2) Remove the valve cover. (ST1T Ø4 × 8L, 3 pcs.) <ul style="list-style-type: none"> • After removing screw, remove the valve cover pulling it downward. 3) Remove wiring cover (PT2T Ø4 × 10L, 1 pc.), and then remove connecting cable. 4) Remove the upper cabinet. (ST1T Ø4 × 8L, 5 pcs.) <ul style="list-style-type: none"> • After taking off screws, remove the upper cabinet pulling it upward. <p>2. Attachment</p> <ol style="list-style-type: none"> 1) Attach the waterproof cover. <hr/> <p style="text-align: center;">CAUTION</p> <p>Be sure to attach a waterproof cover. If it is not attached, there is a possibility that water enters inside of the outdoor unit.</p> <hr/> <ol style="list-style-type: none"> 2) Attach the upper cabinet. (ST1T Ø4 × 8L, 5 pcs.) <ul style="list-style-type: none"> • Hook the rear side of the upper cabinet to claw of the rear cabinet, and then put it on the front cabinet. 3) Perform cabling of connecting cables, and fix with cord clamp. (BT2T Ø4 × 12L, 3 pcs.) 4) Attach the wiring cover. (PT2T Ø4 × 10L, 1 pc.) 5) Attach the valve cover. (ST1T Ø4 × 8L, 3 pcs.) 	 <p>Valve cover</p>  <p>Wiring cover</p>  <p>Upper cabinet</p> <p>Water-proof cover</p> <p>Front cabinet</p>

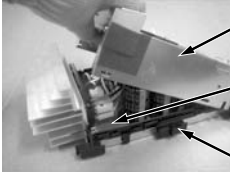

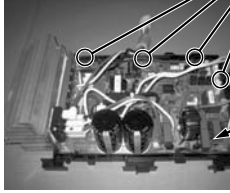
No.	Part name	Procedure	Remarks
②	Front cabinet	<p>1. How to remove</p> <ol style="list-style-type: none"> 1) Perform 1 of ①. 2) Remove the screw between front cabinet and side cabinet (right). (ST1T Ø4 × 8, 1 pc.) 3) Remove the screw between front cabinet and inverter. (ST1T Ø4 × 8, 2 pcs.) 4) Remove the screw between front cabinet and bottom slab. (ST1T Ø4 × 8, 3 pcs.) 5) Remove the screw between front cabinet and motor base. (ST1T Ø4 × 8, 2 pcs.) <ul style="list-style-type: none"> • Left side of front panel is inserted into side cabinet (left). Remove by pulling the upper part. <p>2. How to install</p> <ol style="list-style-type: none"> 1) Insert front panel's hook into side cabinet (left). 2) Insert side cabinet (left)'s hook into front cabinet's corner hole. 3) Insert the removed screws to their positions. 	  

No.	Part name	Procedure	Remarks
③	Inverter assembly	<p>1. Detachment</p> <ol style="list-style-type: none"> 1) Perform work of item 1 of ① . 2) Take off screws of the upper part of the front cabinet. (ST1T Ø4 × 8L, 2 pcs.) <ul style="list-style-type: none"> • If removing the inverter cover under this condition, P.C. board can be checked. • If there is no space in the upper part of the upper cabinet, perform work of ②. <hr/> <p style="text-align: center;">CAUTION</p> <p>Be careful to check the inverter because high-voltage circuit is incorporated in it.</p> <hr/> <ol style="list-style-type: none"> 3) Perform discharging by connecting ⊕ , ⊖ polarities by discharging resistance (approx. 100Ω, 40W) or plug of soldering iron to ⊕ , ⊖ terminals of the C14 (printed as "CAUTION HIGH VOLTAGE") electrolytic capacitor (500μF) of P.C. board. <hr/> <p style="text-align: center;">WARNING</p> <p>The electrolytic capacitor may not normally discharge according to error contents and the voltage may remain. Therefore, be sure to discharge the capacitor.</p> <hr/> <p style="text-align: center;">WARNING</p> <p>For discharging, never use a screwdriver and others for short-circuiting between ⊕ and ⊖ electrodes. As the electrolytic capacitor is one with a large capacity, it is very dangerous because a large electric spark will occur.</p> <hr/> <ol style="list-style-type: none"> 4) Perform 1 of ②. 5) Take off screw between side cabinet (right) and inverter box (wiring gate side) (ST1T Ø4 × 8, 2 pcs.) 6) Take off screw between partition plate and inverter box. (ST1T Ø4 × 8, 1 pc.) 7) Remove each lead wire type from holder of inverter upper part. 8) Pull upper part of inverter. Here, please cut bundling band that tie each lead wire type. 9) Remove connector of each lead wire type. 	 <p>Screws</p>  <p>Front panel</p>  <p>Inverter cover</p>  <p>Cord clamp</p> <p>Screws</p>  <p>Plug of soldering iron</p> <p>Discharging position (Discharging period 10 seconds or more)</p>  

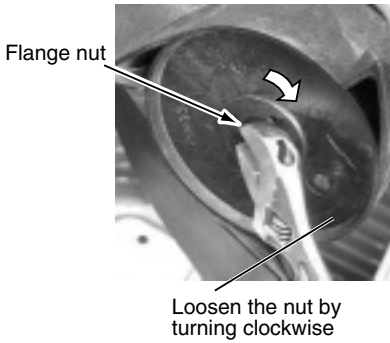
No.	Part name	Procedure	Remarks
③	Inverter assembly	<ul style="list-style-type: none"> • Connector Connection to compressor···(3P : Relay connector white) <li style="text-align: right;">※ (Warning 1) Reactor (2P : Relay connector white) CN300··· Outdoor fan (3P : white) <li style="text-align: right;">※ (Warning 1) CN701··· 4 directional valve (3P : yellow) <li style="text-align: right;">※ (Warning 1) CN700··· PMV coil (6P : white) <li style="text-align: right;">※ (Warning 1) CN601··· TD sensor (3P : white) CN603··· TS sensor (3P : white) <li style="text-align: right;">※ (Warning 1) CN600··· TE sensor (2P : white) <li style="text-align: right;">※ (Warning 1) CN602··· TO sensor (2P : white) CN500··· Case thermo (2P: Blue) <li style="text-align: right;">※ (Warning 1) <p>Warning ※ 1)</p> <p>Please remove housing part's lock before removing connectors.</p> <hr/> <p style="text-align: center;">REQUIREMENT</p> <hr/> <p>As each connector has a lock mechanism, avoid to remove the connector by holding the lead wire, but by holding the connector.</p> <hr/>	 <p style="text-align: right;">Inverter assembly</p>  <p>Remove the connectors with locking function by pushing the part indicated by the arrow mark.</p>

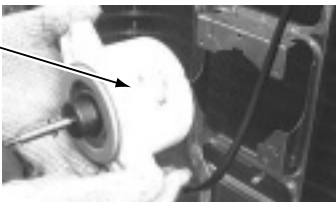

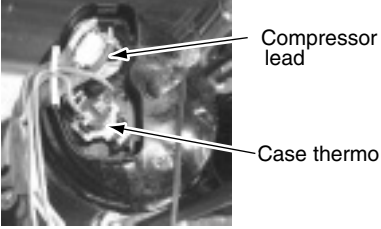
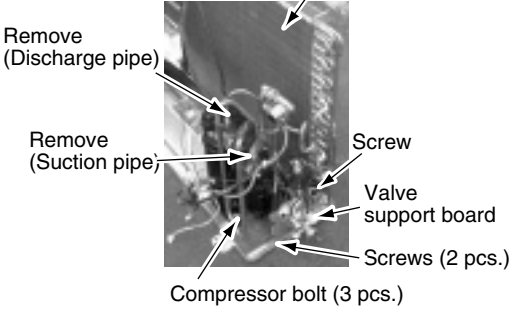
No.	Part name	Procedure	Remarks
④	Control P.C. board assembly	<p>1) Remove sub board base from inverter frame. (BT 2T Ø4 × 10, 2 pcs.) ※ Remove connector of control board frame side.</p> <p>2) Remove lead wire • connector that are connected from control board frame to other parts.</p> <p>1. Lead wire : Connect with terminal block Black, white, orange (single phase), red, white, black, orange (three phase) earthed lines (black)··· 1 pc.</p> <p>2. Connector CN605··· Sub SW board (3P : black) ※ (Warning 1)</p> <p>※ Warning 1) Please remove housing part's lock before removing connectors.</p> <p>3) Remove inverter box (metal plate).</p> <p>4) Remove control board frame from PC board base. (Remove while heat sink is still attached to control board frame)</p> <p>Warning 2) Remove PC board base's hook (4 places), hold heat sink, pull up.</p> <p>5) Take off 2 screws that connect heat sink and control board frame.</p> <p>6) Install new control board frame.</p> <p>Warning 3) When install new control board frame, please correctly insert the board. Make sure to install that heat sink touch metal plate.</p>	 Sub board base  Power line  Remove earth screw  Inverter box (metal plate) Control board frame PC board base  Control board frame PC board base  Hook (4 places)  Inverter box (metal plate) Heat sink

No.	Part name	Procedure	Remarks
⑤	Rear cabinet	1) Perform works of items 1 of ① and ② , ③ . 2) Take off fixed screws for the bottom plate. (ST1T Ø4 × 8L, 2 pcs.) 3) Take off fixed screw for the valve mounting plate. (ST1T Ø4 × 8L, 3 pcs.)	
⑥	Fan motor	1) Perform works of items 1 of ① and ② . 2) Take off the flange nut fixing the fan motor and the propeller. • Turning it clockwise, the flange nut can be loosened. (To tighten the flange nut, turn counterclockwise.) 3) Remove the propeller fan. 4) Disconnect the connector for fan motor from the inverter. 5) Take off the fixing screws (3 pcs.) holding by hands so that the fan motor does not fall. NOTE: Tighten the flange nut with torque 4.9Nm (50kgf/cm).	  

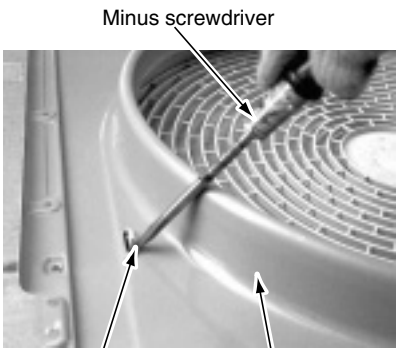
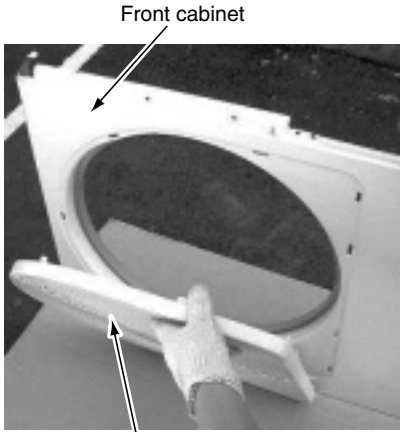
No.	Part name	Procedure	Remarks
⑦	Compressor	<p>1) Perform works of items 1 of ① and ② , ③ , ⑤ .</p> <p>2) Discharge refrigerant gas.</p> <p>3) Remove the partition plate. (ST1T Ø4 × 8L, 3 pcs.)</p> <p>4) Remove the terminal covers of the compressor, and disconnect lead wires of the compressor and the compressor thermo assembly from the terminal.</p> <p>5) Take off the soundproof plate.</p> <p>6) Remove pipes connected to the compressor with a burner.</p> <hr/> <p style="text-align: center;">CAUTION</p> <p>Pay attention to that flame does not involve 4-way valve or PMV. (If doing so, a malfunction may be caused.)</p> <hr/> <p>7) Take off the fixing screws of the bottom plate and heat exchanger. (ST1T Ø4 × 8L)</p> <p>8) Take off the fixing screws of the valve clamping plate to the bottom plate. (ST1T Ø4 × 8L, 2 pcs.)</p> <p>9) Pull upward the refrigerating cycle.</p> <p>10) Take off nut fixing the compressor to the bottom place.</p> <hr/> <p style="text-align: center;">CAUTION</p> <p>When reconnecting the lead wires to the compressor terminals after replacement of the compressor, be sure to caulk the Faston terminal without loosening.</p> <hr/>	<p style="text-align: center;">Partition plate</p>   <p style="text-align: center;">Heat exchanger</p> 
⑧	Reactor	<p>1) Perform works of item 1 of ① , ② and ③ .</p> <p>2) Remove partition plate (ST1T Ø4 × 8L, 3 pcs.)</p> <p>3) Take off screw attached to reactor (ST1T Ø4 × 8L, 5 pcs.)</p>	

No.	Part name	Procedure	Remarks
⑨	Pulse Motor Valve (PMV) coil	<p>1. Detachment</p> <ol style="list-style-type: none"> 1) Perform works of items ① and ② . 2) Release the coil from the concavity by turning it, and remove coil from the PMV. <p>2. Attachment</p> <ol style="list-style-type: none"> 1) Put the coil deep into the bottom position. 2) Fix the coil firmly by turning it to the concavity. 	 <p>PMV coil</p>
⑩	Fan guard	<p>1. Detachment</p> <ol style="list-style-type: none"> 1) Perform works of items 1 of ① and ② . 2) Remove the front cabinet, and put it down so that fan guard side directs downward. <hr/> <p style="text-align: center;">CAUTION</p> <p>Perform works on a corrugated cardboard, cloth, etc. to prevent flaw on the product.</p> <hr/> <ol style="list-style-type: none"> 3) Remove the hooking claws by pushing with minus screwdriver along with the arrow mark in the right figure, and remove the fan guard. <p>2. Attachment</p> <ol style="list-style-type: none"> 1) Insert claws of the fan guard in the hole of the front cabinet. Push the hooking claws (10 positions) with hands and then fix the claws. <hr/> <p style="text-align: center;">CAUTION</p> <p>All the attaching works have completed. Check that all the hooking claws are fixed to the specified positions.</p> <hr/>	 <p>Minus screwdriver</p> <p>Hooking claw</p> <p>Front cabinet</p>  <p>Front cabinet</p> <p>Fan guard</p>

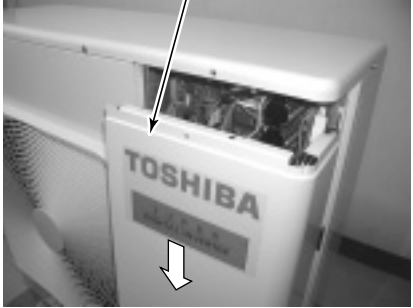
10-2. RAV-SP80*ATP*

No.	Part name	Procedure	Remarks
①	Common procedure	<hr/> <p style="text-align: center;">CAUTION</p> <p>Be sure to put on the gloves at working time; otherwise an injury may be caused by a part, etc.</p> <hr/> <p>1. Detachment</p> <ol style="list-style-type: none"> 1) Stop operation of the air conditioner and then turn off switch of the breaker. 2) Remove the front panel. (Hexagonal screw Ø4 × 10, 2 pcs.) * After removing screws, remove the front panel while pulling it downward. 3) Remove the power wire and indoor/outdoor connecting wire from the cord clamp and the terminals. 4) Remove the top plate. (Hexagonal screw Ø4 × 10, 5 pcs.) <p>2. Attachment</p> <ol style="list-style-type: none"> 1) Attach the top plate. (Hexagonal screw Ø4 × 10, 5 pcs.) In this time, insert the fin guard of rear side between the top plate and the heat exchanger (Rear side). 2) Connect the power supply wire and the indoor/outdoor connecting wire to the terminal and fix it with cord clamp. <hr/> <p style="text-align: center;">CAUTION</p> <p>Using bundling band on the market, be sure to fix the power wire and indoor/outdoor connecting wire along the crossover pipe so that they do not come to contact with the compressor, valve at gas side, pipe at gas side and discharge pipe.</p> <hr/> <ol style="list-style-type: none"> 3) Attach the front panel. (Hexagonal screw Ø4 × 10, 2 pcs.) 	<p style="text-align: center;">Front panel</p>  <p style="text-align: center;">Top plate</p>  <p>Insert the fin guard of rear side between the top plate and the heat exchanger (at rear side).</p> 

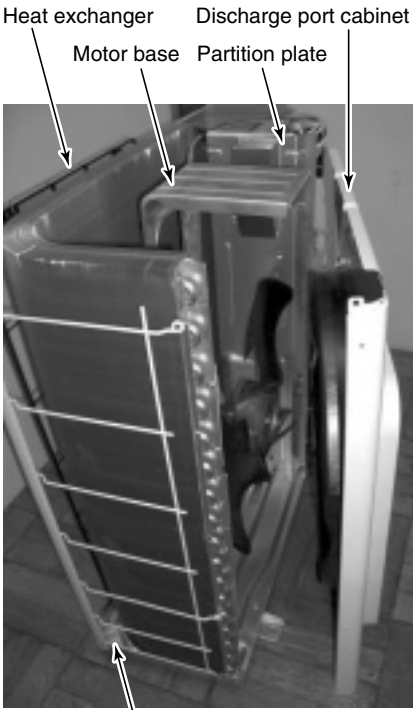
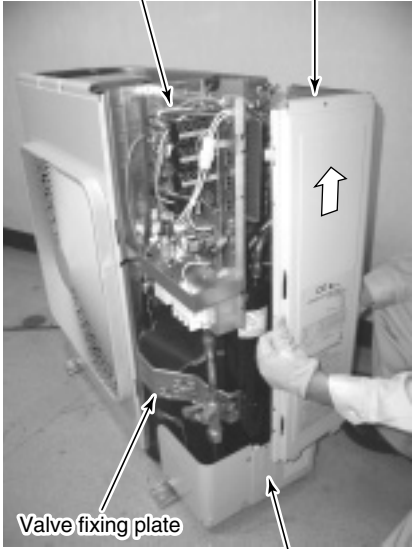
No.	Part name	Procedure	Remarks
②	Discharge port cabinet	<p>1. Detachment</p> <ol style="list-style-type: none"> 1) Carry out work of 1 of ①. 2) Remove screws for the discharge port cabinet and the partition plate. (ST1T Ø4 × 8, 3 pcs.) 3) Remove screws for the discharge port cabinet and the bottom plate. (Hexagonal screw Ø4 × 10, 2 pcs.) 4) Remove screws of the discharge port cabinet and the motor base. (ST1T Ø4 × 8, 2 pcs.) 5) Remove screws of the discharge port cabinet and the heat exchanger. (ST1T Ø4 × 8, 1 pc.) 6) Remove screws of the discharge port cabinet and the fin guard. (Hexagonal screw Ø4 × 10, 2 pcs.) 	 <p>Heat exchanger Discharge port cabinet Motor base Partition plate</p> <p>Fin guard</p>
③	Side cabinet	<ol style="list-style-type: none"> 1) Carry out work of 1 of ①. 2) Remove screws which fix the inverter assembly and the side cabinet. (ST1T Ø4 × 8, 2 pcs.) 3) Remove screws of the side cabinet and the valve fixing plate. (ST1T Ø4 × 8, 2 pcs.) 4) Remove screws of the side cabinet and the pipe panel (Rear). (Hexagonal screw Ø4 × 10, 2 pcs.) 5) Remove screws of the side cabinet and the bottom plate. (Hexagonal screw Ø4 × 10, 1 pc.) 6) Remove screws of the side cabinet and the heat exchanger. (Hexagonal screw Ø4 × 10, 3 pcs.) 7) Slide the side cabinet upward and then remove it. (Hook of inverter) 	 <p>Inverter assembly Side cabinet</p> <p>Valve fixing plate Piping panel (Rear)</p>

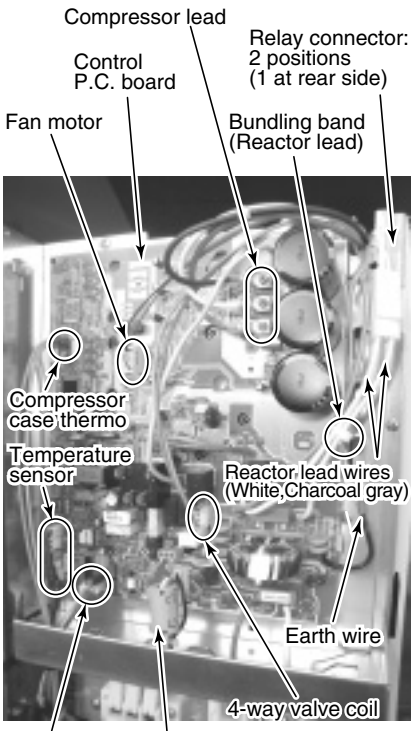
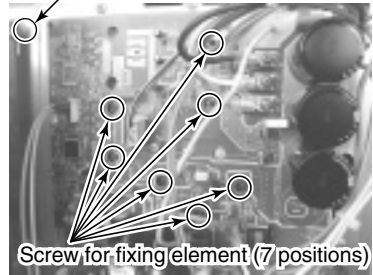
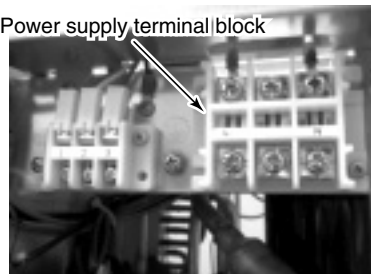
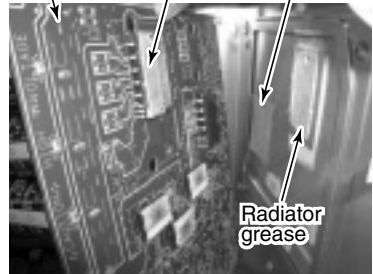
No.	Part name	Procedure	Remarks
④	Exchange of electric parts	<p>1. Control P.C. board</p> <p>1) Carry out work of 1 of ①.</p> <hr/> <p style="text-align: center;">⚠ WARNING</p> <p>Never disassemble the inverter for 1 minute after power has been turned off because an electric shock may be caused.</p> <hr/> <p>2) Remove the connectors connected to the control P.C. board. (Indoor power supply, temperature sensors, PMV coil, 4-way valve coil, compressor case thermo, fan motor) * Unlock the lock of the housing part and then remove the connectors.</p> <p>3) Remove the lead wires connected to the control P.C. board. (Torque at tightening time: $1.47 \pm 0.1\text{N}\cdot\text{m}$)</p> <p>Compressor lead U: CN200 Red V: CN201 White W: CN202 Black</p> <p>Reactor lead Relay connector: 2 positions</p> <p>Remove the power wire from the power supply terminal block. (Torque at tightening time: $2.5 \pm 0.1\text{N}\cdot\text{m}$)</p> <p>4) Remove the earth wire from the control P.C. board. (Truss B tight screw $\varnothing 4 \times 6$, 1 pc.)</p> <p>5) Remove the fixing screws of the control P.C. board. (Screw with collar for fixing element $\varnothing 3 \times 16$, 7 pcs. Pan S tight screw for fixing P.C. board $\varnothing 3 \times 20$, 1 pc.)</p> <p>6) Remove the control P.C. board. (Supporter: 5 positions)</p> <p>NOTE: It is difficult to take out it because of radiator grease for heat sink.</p> <p>7) Mount a new control P.C. board.</p> <p>NOTE: Do not forget to attach the aluminum plate (Q201) and the insulating sheet (Q300). (Applying a little of radiator grease at the rear surface of the insulating sheet in advance to adhere to the heat sink makes easy the work.)</p>	 <p>Compressor lead Control P.C. board Fan motor Relay connector: 2 positions (1 at rear side) Bundling band (Reactor lead) Compressor case thermo Temperature sensor Reactor lead wires (White, Charcoal gray) Earth wire 4-way valve coil PMV coil Indoor power supply</p> <p>Screw for fixing P.C. board</p>  <p>Screw for fixing element (7 positions)</p> <p>Power supply terminal block</p>  <p>Control P.C. board Insulating sheet (Q300) Aluminum plate (Q201) Radiator grease</p> 

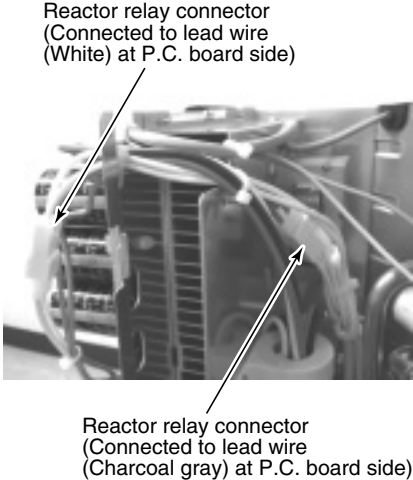
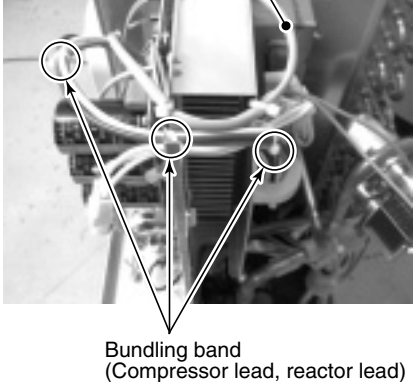
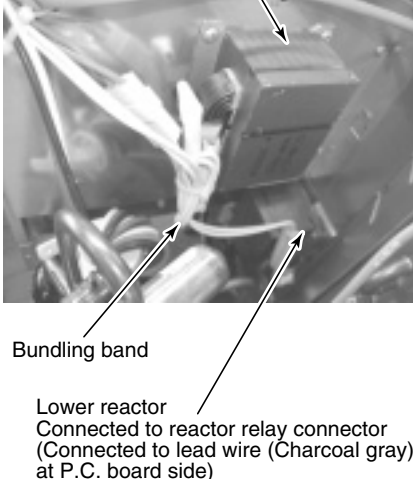
No.	Part name	Procedure	Remarks
④	Exchange of electric parts (Continued)	<p>1. Reactor</p> <ol style="list-style-type: none"> 1) Carry out works of 1 of ① and ③ . 2) Remove the relay connector connected to the control P.C. board. 3) Cut off the bundling band binding the compressor lead and the relay connector. 4) Remove each reactor. (Truss B tight screw $\varnothing 4 \times 6$, 2 pcs. each) 5) Attach a new reactor. <p>NOTE: Be sure to bind the removed bundling band with the bundling band on the market. Be careful that the fan motor lead does not come to contact with the reactor body.</p>	 <p>Reactor relay connector (Connected to lead wire (White) at P.C. board side)</p> <p>Reactor relay connector (Connected to lead wire (Charcoal gray) at P.C. board side)</p> <p>Fan motor lead</p>  <p>Bundling band (Compressor lead, reactor lead)</p> <p>Upper reactor Connected to reactor relay connector (Connected to lead wire (White) at P.C. board side)</p>  <p>Bundling band</p> <p>Lower reactor Connected to reactor relay connector (Connected to lead wire (Charcoal gray) at P.C. board side)</p>

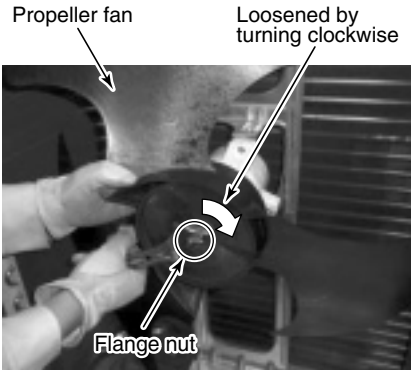
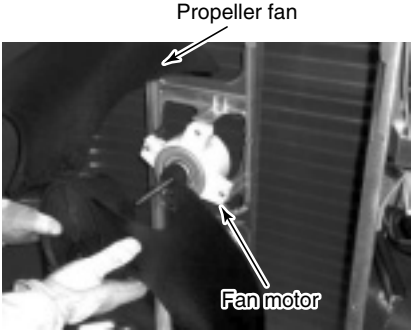
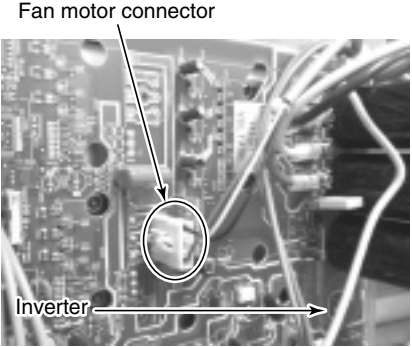
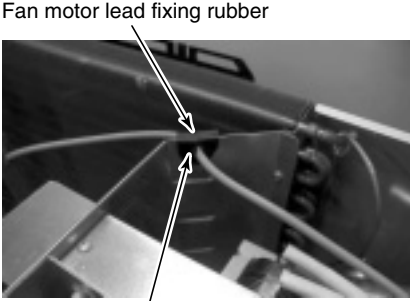
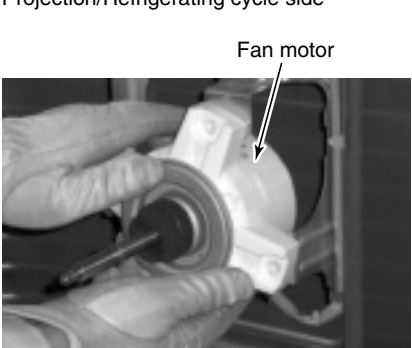
No.	Part name	Procedure	Remarks
⑤	Fan motor	<p>1) Carry out works of 1 of ① and ②.</p> <p>2) Remove the flange nut fixing the fan motor and the propeller fan. * The flange nut is loosened by turning clockwise. (To tighten it, turn it counterclockwise.)</p> <p>3) Remove the propeller fan.</p> <p>4) Remove the connector for fan motor from the inverter.</p> <p>5) Remove the fan motor lead from the fan motor lead fixing rubber of the penetrated part of the partition plate.</p> <p>6) Remove the fixing screws (4 pcs. each) while supporting the fan motor so that it does not fall.</p> <p>* Cautions when assembling the fan motor</p> <ul style="list-style-type: none"> * Tighten the flange nut with 4.95N•m (50kgf.cm). * Adjust length on the fan motor lead fixing rubber so that the fan motor lead does not slacken in order not to put the fan motor lead into contact with the propeller fan. <p>Attach the fan motor lead fixing rubber to the partition plate so that projection directs to the refrigerating cycle side.</p> <ul style="list-style-type: none"> * Be sure that the rector body does not come to contact with the fan motor lead. * Be sure to bind the removed bundling band with the bundling band on the market. <hr/> <p style="text-align: center;">⚠ CAUTION</p> <p>Use the metal band of the motor base to fix the fan motor lead on the motor base so that the fan motor lead does not come to contact with the propeller fan.</p> <hr/>	    

No.	Part name	Procedure	Remarks
⑥	Compressor Compressor lead	<p>1. Removal of broken compressor</p> <ol style="list-style-type: none"> 1) Recover the refrigerant gas. 2) Carry out works of 1 of ① and ② , ③ . 3) Remove the piping panel (Front). Remove screws of the piping panel (Front) and the bottom plate. (Hexagonal screw $\varnothing 4 \times 10$, 2 pcs.) Remove screws of the piping panel (Front) and the piping panel (Rear). (Hexagonal screw $\varnothing 4 \times 10$, 1 pc.) 4) Remove the piping panel (Rear). Remove screws of the piping panel (Rear) and the bottom plate. (Hexagonal screw $\varnothing 4 \times 10$, 2 pcs.) 5) Remove the valve fixing plate. Remove bolts of the valve. (Hexagonal screw $\varnothing 6 \times 15$, 4 pcs.) Remove screws of the valve fixing plate and the partition plate. (ST1T $\varnothing 4 \times 8$, 1 pc.) Remove screws of the valve fixing plate and the accumulator. (ST1T $\varnothing 4 \times 8$, 1 pc.) Cut off the bundling band for the discharge pipe and the suction pipe and then remove each sensor and coil lead of PMV. 6) Remove the soundproof plate. (Upper side, outer winding, inner winding) 7) Remove terminal cover from the compressor and then remove the compressor lead and also the compressor case thermo. 8) Remove TD sensor fixed to the discharge pipe. 9) Remove the compressor lead. (Leave the ferrite core attached to the electric parts box as it is.) <p>Control P.C. board</p> <p>U : CN200 Red V : CN201 White W : CN202 Black (Tightening torque: $1.47 \pm 0.1\text{N}\cdot\text{m}$)</p>	<p>Piping panel (Front) Piping panel (Rear)</p> <p>Bundling band for heat proof TD sensor Pipe cover</p> <p>Compressor lead Compressor case thermo</p> <p>TS sensor Pipe cover, bundling band Suction pipe Discharge pipe Accumulator</p> <p>Pipe cover, bundling band, each sensor (TL, TO, TE, TD, TS sensors) PMV coil lead</p> <p>Black pipe cover for heat proof, bundling band for heat proof, each sensor (TL, TO, TE, TD, TS sensors) PMV coil lead</p> <p>Control P.C. board Compressor lead</p> <p>Compressor lead Ferrite core</p>

No.	Part name	Procedure	Remarks
⑥	Compressor Compressor lead (Continued)	<p>10) Using a burner, remove the discharge pipe and the suction pipe connected to the compressor.</p> <hr/> <p style="text-align: center;">⚠ WARNING</p> <p>In case of removing the piping by broiling the welded part with a burner, if the piping includes oil, it may burst into flames at the moment when wax melted, so take sufficient care.</p> <hr/> <p style="text-align: center;">⚠ CAUTION</p> <p>Note so that the flame does not catch the 4-way valve and PMV. (An operation may become an error.)</p> <hr/> <p>11) Pull off the discharge pipe and the suction pipe of the refrigerating cycle upward.</p> <p>12) Remove the compressor bolts which fix the compressor to the bottom plate. (3 pcs.)</p> <p>13) Pull out the compressor toward you.</p> <hr/> <p style="text-align: center;">⚠ CAUTION</p> <p>The weight of the compressor is 15kg or more, so handle it by 2 workers.</p> <hr/>	<p>Remove (Discharge pipe) Remove (Suction pipe)</p>  <p>Compressor bolt (3 pcs.)</p>

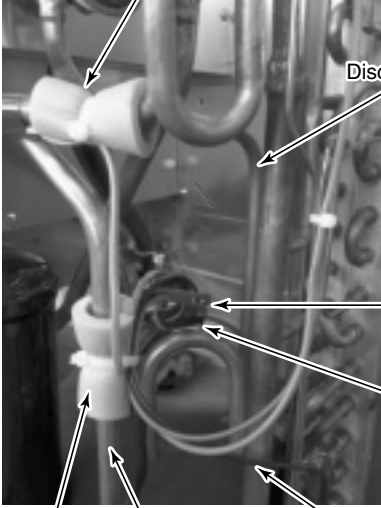
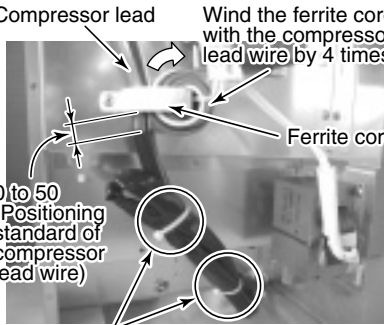
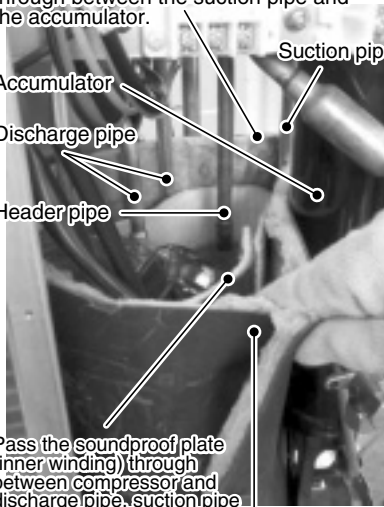
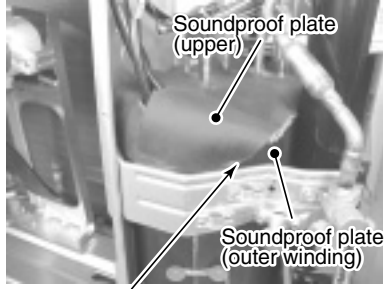
No.	Part name	Procedure	Remarks
⑥	Compressor Compressor lead (Continued)	<p>2. Mounting of compressor</p> <p>1) Mount the compressor in the reverse procedure of removal.</p> <p>NOTES:</p> <ul style="list-style-type: none"> * After exchange of the compressor, be sure to exchange the compressor lead. (Repair part code of compressor lead: 43160591) In this time, wrap the ferrite core with the compressor lead wire by 4 times. Using bundling band on the market, bind the compressor lead. As the compressor lead is long, be sure that the compressor lead does not contact with the discharge pipe. * Fix the removed each sensor and PMV coil lead wire to the discharge pipe and the suction pipe with the bundling band via the pipe cover. In this time, take note that each sensor and PMV coil lead wire do not come to contact with the discharge pipe and the reactor. (For fixing to the discharge pipe, use the black heat-proof pipe cover and the bundling band for heat-proof which is sold on the market.) * As shown in the right figure, mount the soundproof plate (inner winding, outer winding) by inserting between the compressor and the piping, and between piping and the partition plate. * Put the compressor lead wire and the compressor case thermo between inner winding and outer winding of the soundproof as if dropping them in. <p>Pipe cover, bundling band, TS sensor</p>  <p>Discharge pipe</p> <p>Suction pipe</p> <p>PMV coil lead</p> <p>Pipe cover, bundling band, each sensor (TL, TO, TE, TS sensor) PMV coil lead</p>	 <p>Compressor lead</p> <p>Wind the ferrite core with the compressor lead wire by 4 times.</p> <p>Ferrite core</p> <p>0 to 50 (Positioning standard of compressor lead wire)</p> <p>Using the bundling band on the market, fix the bundle at 2 positions.</p> <p>Pass the soundproof plate (outer winding) through between the suction pipe and the accumulator.</p>  <p>Suction pipe</p> <p>Accumulator</p> <p>Discharge pipe</p> <p>Header pipe</p> <p>Pass the soundproof plate (inner winding) through between compressor and discharge pipe, suction pipe and then put it on the other side at this position.</p> <p>Put the soundproof plate (outer winding) on the other side at this position.</p>  <p>Soundproof plate (upper)</p> <p>Soundproof plate (outer winding)</p> <p>Do not make clearance between the soundproof plate (upper) and the soundproof plate (outer winding).</p> <p>Black heat-proof pipe cover and heat-proof bundling band, each sensor (TL, TO, TE, TD, TS sensor) PMV coil lead wire</p> <p>Set each sensor so that it does not come to contact with the discharge pipe.</p>

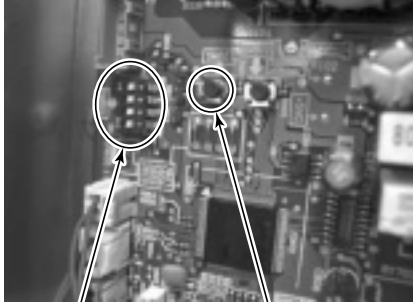
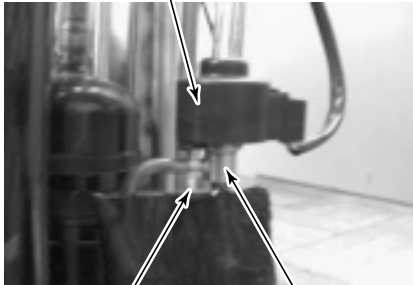
No.	Part name	Procedure	Remarks
⑥	Compressor Compressor lead (Continued)	<p>3. Vacuuming</p> <ol style="list-style-type: none"> 1) Connect the vacuum pump to the charge port of the gas pipe valve and then drive the vacuum pump. 2) Carry out vacuuming until the vacuum low pressure gauge indicates 1 (mmHg). <p>NOTE: Before vacuuming, open PMV fully. If PMV is closed, vacuuming may be impossible between the liquid pipe valve and PMV of the outdoor unit.</p> <p>Forced full-opening method of PMV</p> <ul style="list-style-type: none"> * Turn on the leakage breaker. * Turn on 1 and 3 of DIP SW804 on the control P.C. board of the outdoor unit. * Keep pushing SW801 on the control P.C. board of the outdoor unit for 1 second or more. * After pushing SW801 for 1 second or more, turn off the leakage breaker within 2 minutes. <p>4. Refrigerant charging</p> <ol style="list-style-type: none"> 1) Add the quantity of refrigerant specified by the pipe length into the charge port of the valve. 	 <p style="text-align: center;">SW804 SW801</p>
⑦	PMV coil	<p>1. Detachment</p> <ol style="list-style-type: none"> 1) Carry out works of 1 of ① and ③. 2) While pulling the coil upward and removing the spring which pinches the copper pipe, remove the coil from PMV main body. <p>2. Attachment</p> <ol style="list-style-type: none"> 1) Match the spring to the copper pipe and fix it. 	 <p style="text-align: center;">PMV coil Spring PMV main body</p>

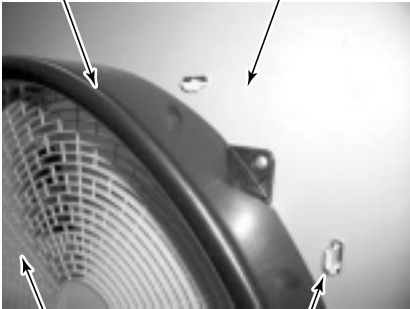
No.	Part name	Procedure	Remarks
⑧	Fan guard	<p>3. Detachment</p> <p>1) Carry out works of 1 of ① and ②.</p> <hr/> <p style="text-align: center;">CAUTION</p> <hr/> <p>To prevent scratching on the product, handle the product on a cardboard or cloth.</p> <hr/> <p>2) Remove the discharge port cabinet and then put on it so that the fan guard side directs downward.</p> <p>3) Remove the hooking claws (8 positions) of the fan guard.</p> <p>2. Attachment</p> <p>1) Push the hooking claws (8 positions) with hands from the front side to fix the claws.</p> <hr/> <p style="text-align: center;">CAUTION</p> <hr/> <p>Check that all the hooking claws are fixed at the specified positions.</p> <hr/>	<p>Bell mouth Discharge port cabinet</p>  <p>Fan guard Hooking claw</p>

11. EXPLODED VIEWS AND PARTS LIST

11-1. RAV-SP404ATP-E, SP454ATP-E

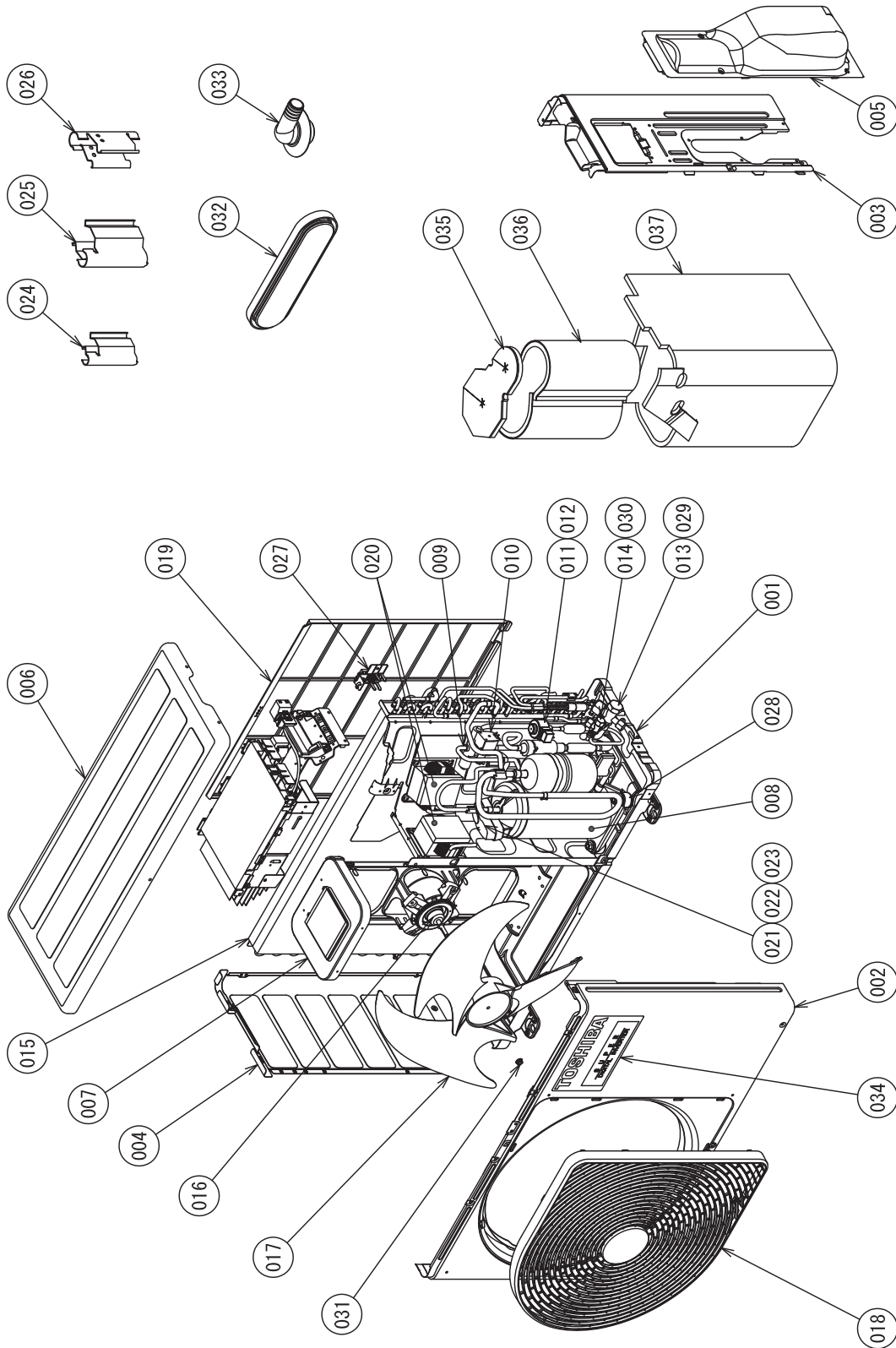

Location No.	Part No.	Description	RAV-	
			SP404ATP-E	SP454ATP-E
001	43T42352	BASE PLATE ASSEMBLY	1	1
002	43T00605	FRONT PANEL CABINET ASSEMBLY	1	1
003	43T00599	RIGHT PANEL CABINET ASSEMBLY	1	1
004	43T00603	LEFT PANEL CABINET ASSEMBLY	1	1
005	43T19352	PACKED VALVE COVER ASSEMBLY	1	1
006	43T00604	UPPER CABINET ASSEMBLY	1	1
007	43T39348	MOTOR BASE	1	1
008	43T41627	COMPRESSOR, DA150A1F-20F	1	1
009	43T46375	VALVE, 4WAY	1	1
010	43T63337	COIL, VALVE, 4WAY	1	1
011	43T46389	VALVE, PULSE, MODULATING	1	1
012	43T63329	COIL, PMV	1	1
013	43T46374	VALVE, PACKED, 12.7 DIA	1	1
014	43T46358	VALVE, PACKED, 6.35 DIA	1	1
015	43T43474	CONDENSER ASSEMBLY	1	1
016	43T21375	FAN MOTOR	1	1
017	43T20319	PROPELLER FAN	1	1
018	43T19329	FAN GUARD	1	1
019	43T19331	FIN GUARD	1	1
020	43T58306	REACTOR	2	2
021	43T60420	COMPRESSOR LEAD ASSEMBLY	1	1
022	43T54319	THERMOSTAT, BIMETAL	1	1
023	43T50307	HOLDER, THERMOSTAT	1	1
024	43T63317	HOLDER, SENSOR	1	1
025	43T63323	HOLDER, SENSOR	1	1
026	43T63318	HOLDER, SENSOR	1	1
027	43T63319	HOLDER, SENSOR	1	1
028	43T49335	CUSHION, RUBBER	3	3
029	43T47333	BONNET, 12.7 DIA	1	1
030	43T47331	BONNET, 6.35 DIA	1	1
031	43047669	NUT FLANGE	1	1
032	43039160	WATERPROOF CAP	2	2
033	43T79305	DRAIN NIPPLE	1	1
034	43T85529	MARK, TOSHIBA	1	1
035	43T04315	SOUNDPROOF COVER, UP	1	1
036	43T04316	SOUNDPROOF COVER, INSIDE	1	1
037	43T04317	SOUNDPROOF COVER, OUTSIDE	1	1

<Inverter assembly>

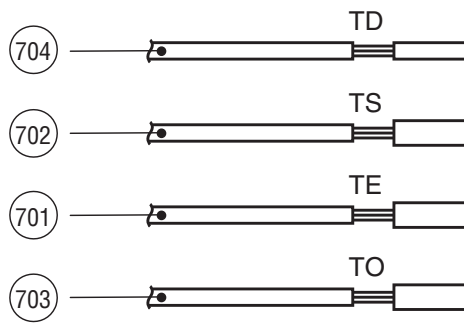
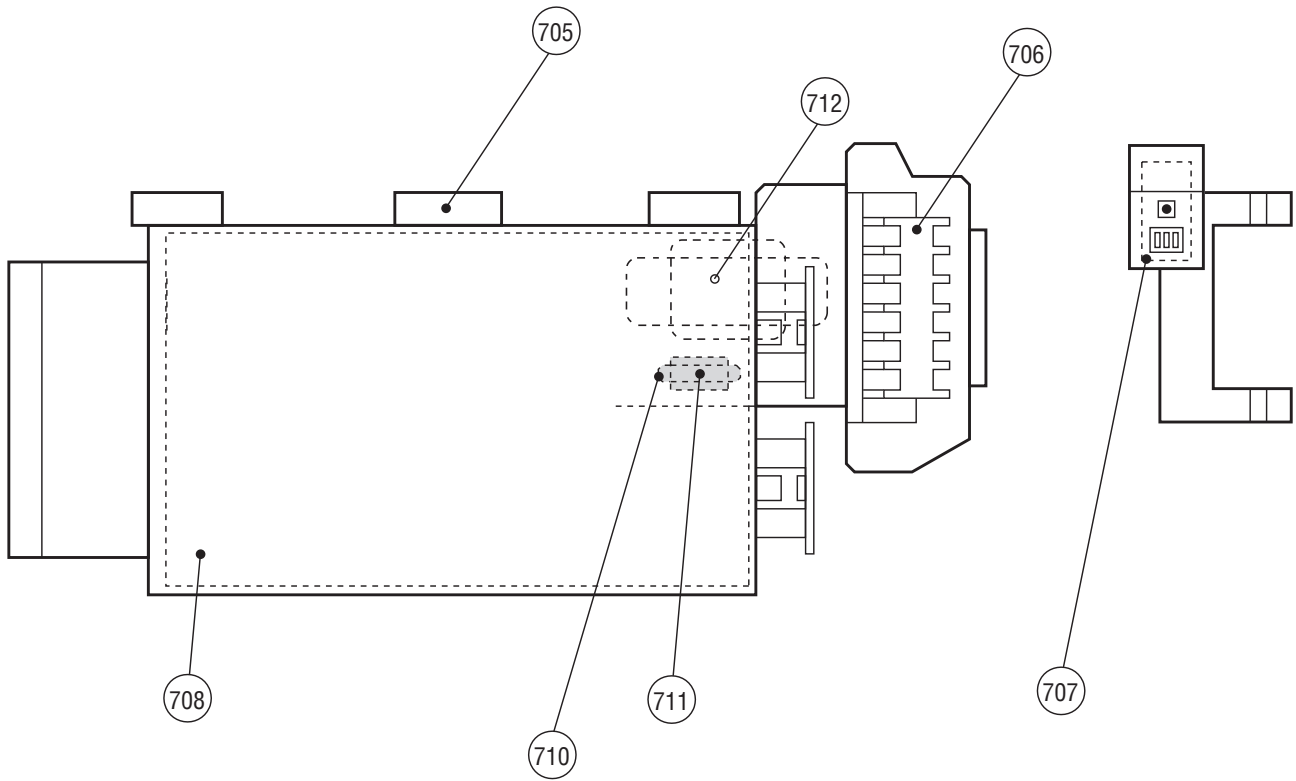

Location No.	Part No.	Description	RAV-	
			SP404ATP-E	SP454ATP-E
701	43T60428	Sensor, TE	1	1
702	43T60429	Sensor, TS	1	1
703	43T60430	Sensor, TO	1	1
704	43T60431	Sensor, TD	1	1
705	43T62313	Base Plate PC	1	1
706	43T60423	ASM SERV Terminal block, 6P, 20A	1	1
707	43T6V363	P.C.board Ass'y, SW, MCC-1530	1	1
708	43T6V362	P.C.board Ass'y, MCC-5009	1	1
710	43T60425	Fuse holder, 15A, 250V	1	1
711	43T60426	Fuse, 6.3A, 250VAC	1	1
712	43T60422	Reactor, CH-76-TM1	1	1

11-2. SP564ATP-E, SP564ATJP-E

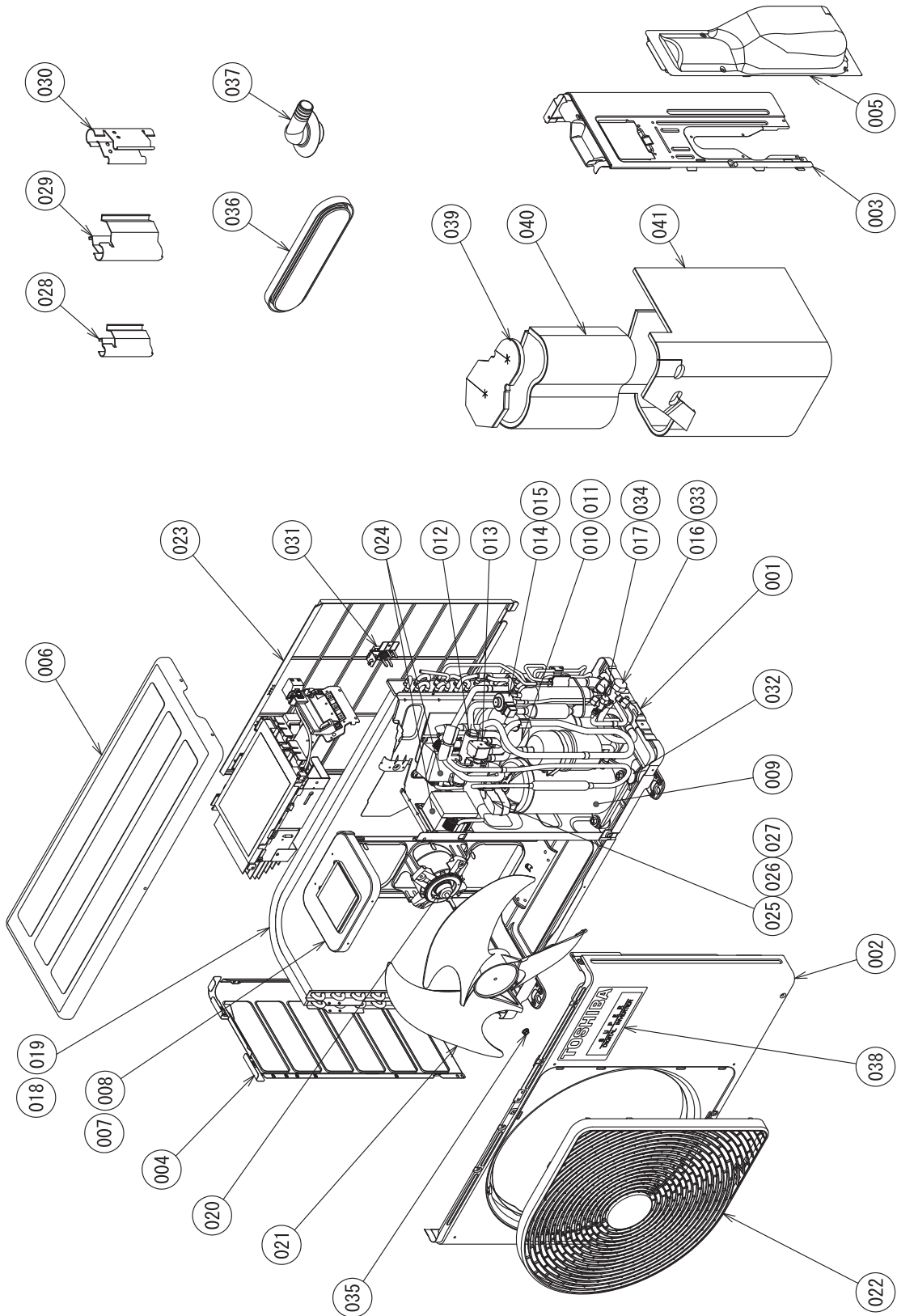

Location No.	Part No.	Description	RAV-	
			SP564ATP-E	SP564ATJP-E
001	43T42352	BASE PLATE ASSEMBLY	1	1
002	43T00605	FRONT PANEL CABINET ASSEMBLY	1	1
003	43T00599	RIGHT PANEL CABINET ASSEMBLY	1	1
004	43T00602	LEFT PANEL CABINET ASSEMBLY	1	1
005	43T19352	PACKED VALVE COVER ASSEMBLY	1	1
006	43T00604	UPPER CABINET ASSEMBLY	1	1
007	43T39348	MOTOR BASE	1	
008	43T39347	MOTOR BASE		1
009	43T41451	COMPRESSOR, DA150A1F-21F	1	1
010	43T48302	ACCUMULATOR ASSEMBLY	1	
011	43T48303	ACCUMULATOR ASSEMBLY		1
012	43T46383	VALVE, 4WAY	1	1
013	43T63337	COIL, VALVE, 4WAY	1	1
014	43T46389	VALVE, PULSE, MODULATING	1	1
015	43T63329	COIL, PMV	1	1
016	43T46374	VALVE, PACKED, 12.7 DIA	1	1
017	43T46358	VALVE, PACKED, 6.35 DIA	1	1
018	43T43471	CONDENSER ASSEMBLY	1	
019	43T43470	CONDENSER ASSEMBLY		1
020	43T21375	FAN MOTOR	1	1
021	43T20319	PROPELLER FAN	1	1
022	43T19329	FAN GUARD	1	1
023	43T19331	FIN GUARD	1	1
024	43T58306	REACTOR	2	2
025	43T60420	COMPRESSOR LEAD ASSEMBLY	1	1
026	43T54319	THERMOSTAT, BIMETAL	1	1
027	43T50307	HOLDER, THERMOSTAT	1	1
028	43T63317	HOLDER, SENSOR	1	1
029	43T63323	HOLDER, SENSOR	1	1
030	43T63318	HOLDER, SENSOR	1	1
031	43T63319	HOLDER, SENSOR	1	1
032	43T49335	CUSHION, RUBBER	3	3
033	43T47333	BONNET, 12.7 DIA	1	1
034	43T47331	BONNET, 6.35 DIA	1	1
035	43047669	NUT FLANGE	1	1
036	43039160	WATERPROOF CAP	2	2
037	43T79305	DRAIN NIPPLE	1	1
038	43T85529	MARK, TOSHIBA	1	1
039	43T04315	SOUNDPROOF COVER, UP	1	1
040	43T04316	SOUNDPROOF COVER, INSIDE	1	1
041	43T04317	SOUNDPROOF COVER, OUTSIDE	1	1

<Inverter assembly>

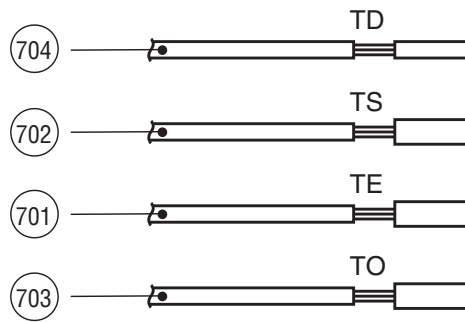
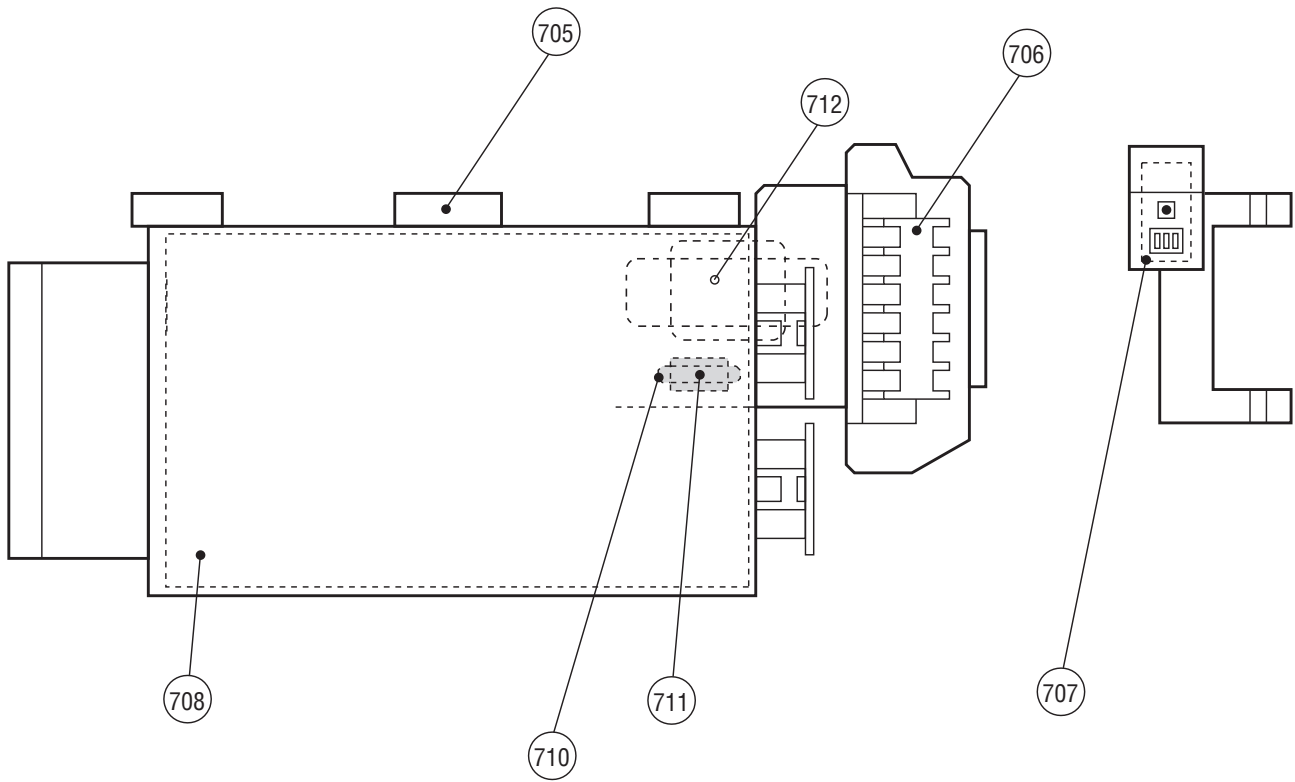

Location No.	Part No.	Description	RAV-	
			SP564ATP-E	SP564ATJP-E
701	43T60428	Sensor, TE	1	1
702	43T60429	Sensor, TS	1	1
703	43T60430	Sensor, TO	1	1
704	43T60431	Sensor, TD	1	1
705	43T62313	Base Plate PC	1	1
706	43T60423	ASM SERV Terminal block, 6P, 20A	1	1
707	43T6V363	P.C.board Ass'y, SW, MCC-1530	1	1
708	43T6V362	P.C.board Ass'y, MCC-5009	1	1
710	43T60425	Fuse holder, 15A, 250V	1	1
711	43T60426	Fuse, 6.3A, 250VAC	1	1
712	43T60422	Reactor, CH-76-TM1	1	1

11-3. RAV-SP804ATP-E, SP804ATJP-E

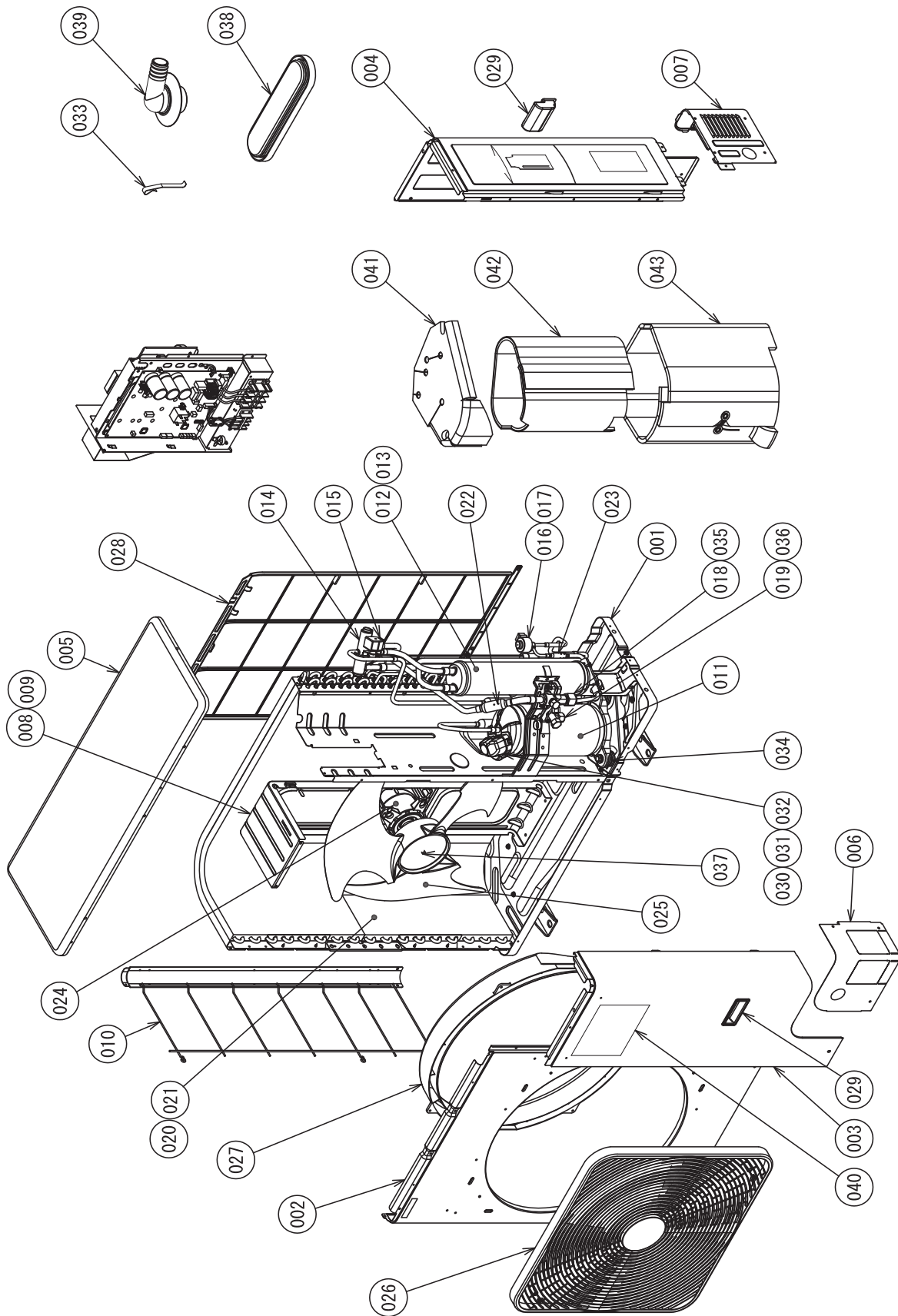

Location No.	Part No.	Description	RAV-	
			SP804ATP-E	SP804ATJP-E
001	43T42351	BASE PLATE ASSEMBLY	1	1
002	43T00606	AIR OUTLET CABINET	1	1
003	43T00601	FRONT PANEL CABINET ASSEMBLY	1	1
004	43T00607	RIGHT PANEL CABINET ASSEMBLY	1	1
005	43T00600	UPPER CABINET ASSEMBLY	1	1
006	43T00608	FRONT PANEL PIPING CABINET	1	1
007	43T00609	BACK PANEL PIPING CABINET	1	1
008	43T39342	MOTOR BASE	1	
009	43T39349	MOTOR BASE		1
010	43T19346	GUARD FIN ASSEMBLY	1	1
011	43T41445	COMPRESSOR, DA220A2F-22L	1	1
012	43T48301	ACCUMULATOR ASSEMBLY	1	
013	43T48304	ACCUMULATOR ASSEMBLY		1
014	43T46383	VALVE, 4WAY	1	1
015	43T63344	COIL, VALVE, 4WAY	1	1
016	43T46382	VALVE, PULSE, MODULATING	1	1
017	43T46338	COIL, PMV	1	1
018	43T46381	VALVE, BALL, 15.88 DIA	1	1
019	43T46380	VALVE, PACKED, 9.52 DIA	1	1
020	43T43472	CONDENSER ASSEMBLY	1	
021	43T43473	CONDENSER ASSEMBLY		1
022	43T47372	STRAINER, 25.4 DIA	1	1
023	43T47373	STRAINER, 12.7 DIA	1	1
024	43T21429	FAN MOTOR	1	1
025	43T20329	PROPELLER FAN	1	1
026	43T19343	FAN GUARD	1	1
027	43T22313	BELLMOUTH	1	1
028	43T19345	FIN GUARD	1	1
029	43T71302	HANDLE	2	2
030	43T60421	COMPRESSOR LEAD ASSEMBLY	1	1
031	43T54319	THERMOSTAT, BIMETAL	1	1
032	43T50307	HOLDER, THERMOSTAT	1	1
033	43T19333	HOLDER, SENSOR	1	1
034	43T49346	CUSHION, RUBBER	3	3
035	43T47334	BONNET, 15.88 DIA	1	1
036	43T47332	BONNET, 9.52 DIA	1	1
037	43T39346	NUT FLANGE	1	1
038	43T79317	WATERPROOF CAP	5	5
039	43T79305	DRAIN NIPPLE	1	1
040	43T85529	MARK, TOSHIBA	1	1
041	43T04314	SOUNDPROOF COVER, UP	1	1
042	43T04312	SOUNDPROOF COVER, INSIDE	1	1
043	43T04313	SOUNDPROOF COVER, OUTSIDE	1	1

<Inverter assembly>

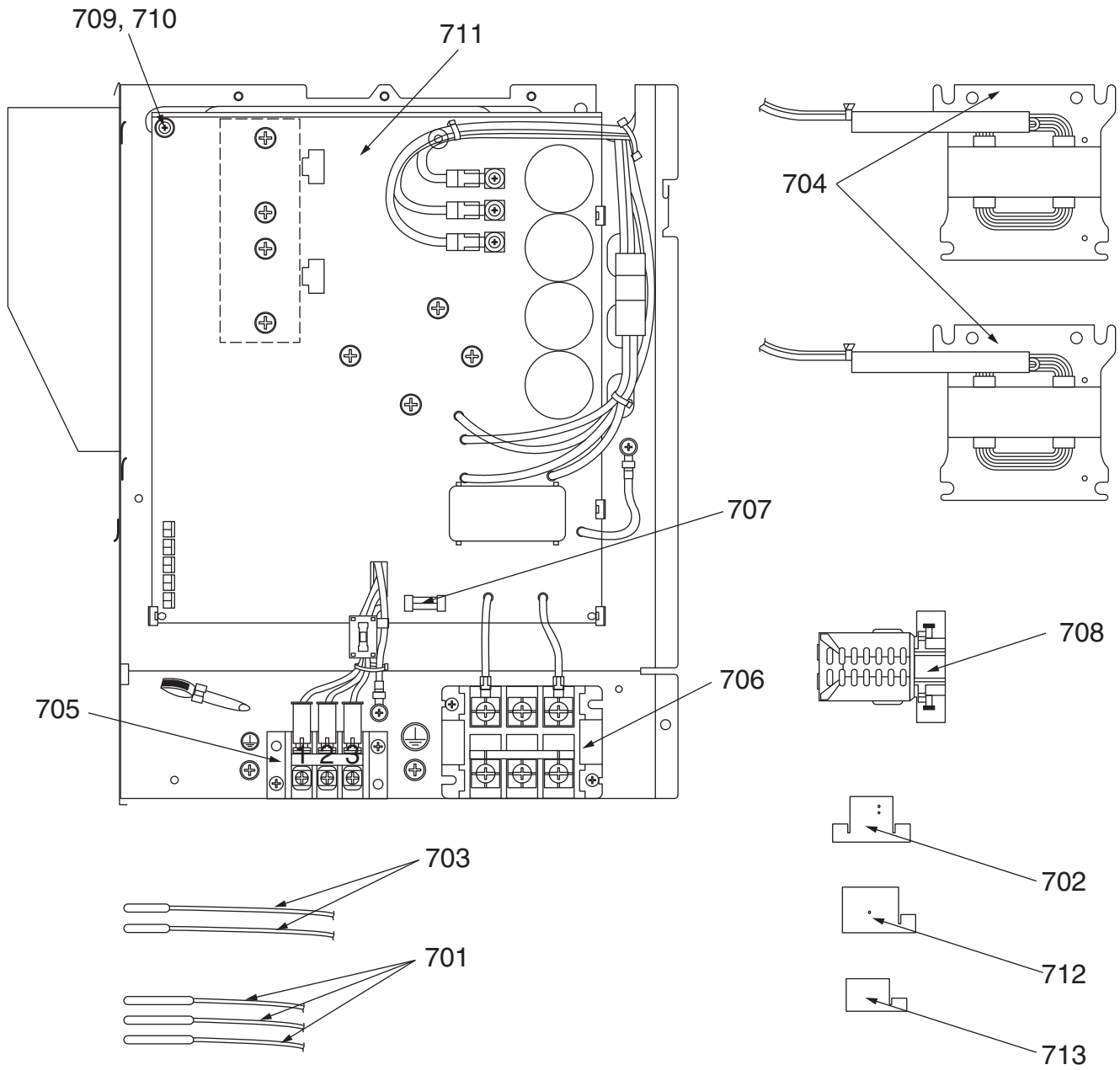

Location No.	Part No.	Description	RAV-	
			SP804ATP-E	SP804ATJP-E
701	43T60432	Sensor Ass'y, Ø6	3	3
702	43T63318	Holder, Sensor (TE)	1	1
703	43T60433	Sensor Ass'y, Ø4	2	2
704	43T58307	Reactor, CH-56-2Z-T	2	2
705	43T60427	ASM SERV Terminal block, 3P, 20A	1	1
706	43T60424	ASM SERV Terminal block, 3P, 60A	1	1
707	43T60413	Fuse, 10A, 250V AC	1	1
708	43T63335	Holder, Sensor (TO)	1	1
709	43T61315	Spacer, Bush	1	1
710	43T61316	Spacer, Collar	1	1
711	43T6V361	P.C.board Ass'y, MCC-1571	1	1
712	43T63323	Holder, Sensor (TS)	1	1
713	43T63317	Holder, Sensor (TD)	1	1

WARNINGS ON REFRIGERANT LEAKAGE

Check of Concentration Limit

The room in which the air conditioner is to be installed requires a design that in the event of refrigerant gas leaking out, its concentration will not exceed a set limit.

The refrigerant R410A which is used in the air conditioner is safe, without the toxicity or combustibility of ammonia, and is not restricted by laws to be imposed which protect the ozone layer. However, since it contains more than air, it poses the risk of suffocation if its concentration should rise excessively. Suffocation from leakage of R410A is almost non-existent.

If a conditioner system is to be installed in a small room, select a suitable model and installation procedure so that if the refrigerant accidentally leaks out, its concentration does not reach the limit (and in the event of an emergency, measures can be made before injury can occur).

In a room where the concentration may exceed the limit, create an opening with adjacent rooms, or install mechanical ventilation combined with a gas leak detection device.

The concentration is as given below.

$$\frac{\text{Total amount of refrigerant (kg)}}{\text{Min. volume of the indoor unit installed room (m}^3\text{)}} \leq \text{Concentration limit (kg/m}^3\text{)}$$

The concentration limit of R410A which is used in air conditioners is 0.3kg/m³.

NOTE

The minimum indoor floor area compared with the amount of refrigerant is roughly as follows:
(When the ceiling is 2.7m high)

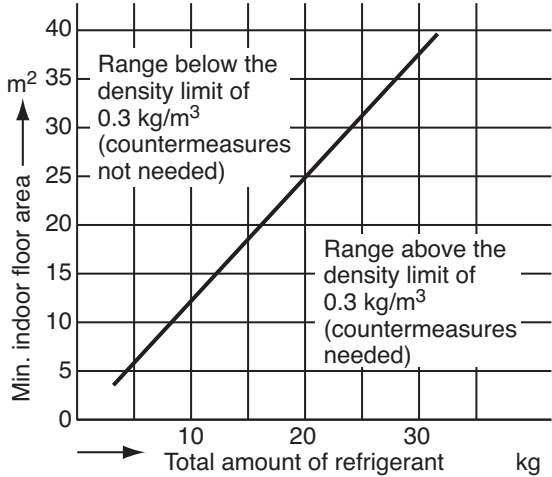

TOSHIBA CARRIER (THAILAND) CO.,LTD.

144/9 MOO 5, BANGKADI INDUSTRIAL PARK, TIVANON ROAD, TAMBOL BANGKADI,
AMPHUR MUANG, PATHUMTHANI 12000, THAILAND.